



**⚠ Read this manual carefully before operating the system.
This manual should stay with this system if it is sold.**

OWNER'S MANUAL

Drive Unit Display Unit Battery Pack Battery Charger

* This owner's manual is original instruction.

* Product and specifications are subject to change without notice.

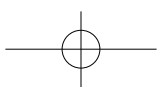
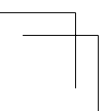
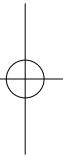
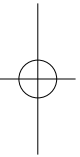

Introduction

These original instructions have been prepared for your Drive Unit, Display Unit, Battery Pack and Battery Charger.

TIP

This manual is not intended as a comprehensive use, service, repair or maintenance manual. Please see your dealer for all service, repairs or maintenance. Your dealer may also be able to refer you to classes, clinics or books on bicycle use, service, repair or maintenance.

**Drive Unit, Display Unit,
Battery Pack, Battery Charger
OWNER'S MANUAL
©2022 by Yamaha Motor Co., Ltd.
1st edition, January 2022
All rights reserved.
Any reprinting or unauthorized use
without the written permission of
Yamaha Motor Co., Ltd.
is expressly prohibited.**





Contents

General warning	p.	1
1. Electric bike components	p.	2
A. Introduction	p.	2
B. Consumer information	p.	2
Drive Unit data recording	p.	2
C. Location of the warning and specification labels	p.	3
D. Description	p.	4
E. e-Bike Systems	p.	5
The e-Bike Systems are designed to give you the optimal amount of power assist.	p.	5
Multiple power assist modes are available.	p.	5
Conditions that could decrease range (remaining assist distance)	p.	6
F. ⚠ Safety information	p.	7
G. Instrument and control functions	p.	10
Display Unit (Display A)	p.	10
Display Unit (Display C)	p.	17
Display Unit (Interface X)	p.	43
H. Battery Pack and charging procedure	p.	54
Appropriate charging environments	p.	55
Inappropriate charging environments and solutions	p.	55
Charging the Battery Pack mounted on the bicycle (Rear Carrier Battery)	p.	56
Charging the Battery Pack mounted on the bicycle (Down Tube Battery)	p.	56
Charging the Battery Pack mounted on the bicycle (Multi Location Battery, External Crossover Battery)	p.	56
Charging the Battery Pack removed from the bicycle	p.	58
Reading the charging status for Battery Pack	p.	64
Reading the charging status for Display Unit (Applies only to models equipped with the Multi Location Battery.)	p.	66
Charging time guidelines	p.	68
I. Checking the residual battery capacity	p.	69
Residual battery capacity indicator display and estimate of residual battery capacity for Display Unit	p.	69
Display of the battery capacity indicator lamps and the estimate of the residual battery capacity	p.	71
J. Pre-operation check	p.	74
K. Cleaning, maintenance and storage	p.	74
Caring for the Battery Pack	p.	74
Maintenance for the Drive Unit	p.	75
Storage	p.	75
Long storage period (1 month or longer) and using it again after a long storage period	p.	75
L. Transport	p.	75
M. Disposal	p.	76
N. Simplified declaration of conformity	p.	76
O. Troubleshooting	p.	77
e-Bike Systems	p.	77
Walk assist function	p.	84
Power supply of external devices via USB connection	p.	85
Wireless communication	p.	86
Battery Pack and Battery Charger	p.	87
P. Specifications	p.	91

General warning

FAILURE TO FOLLOW THE WARNINGS CONTAINED IN THIS MANUAL CAN RESULT IN SERIOUS INJURY OR DEATH.

Particularly important information is distinguished in this manual by the following notations:

	This is the safety alert symbol. It is used to alert you to potential personal injury hazards. Obey all safety messages that follow this symbol to avoid possible injury or death.
	A WARNING indicates a hazardous situation which, if not avoided, could result in death or serious injury.
	A NOTICE indicates special precautions that must be taken to avoid damage to the vehicle or other property.
	A TIP provides key information to make procedures easier or clearer.

1. Electric bike components

A. Introduction

Bluetooth®



The Bluetooth® word mark and logos are registered trademarks owned by the Bluetooth SIG, Inc. and any use of such marks by YAMAHA MOTOR CO., LTD. is under license.

* Applies to Display C and Interface X.

ANT+™



Featuring certified wireless ANT+™ connectivity.
Visit www.thisisant.com/directory for compatible products.

* Applies to Interface X.

B. Consumer information

Drive Unit data recording

This model stores certain Drive Unit data to assist in the diagnosis of malfunctions and for research, statistical analysis and development purposes.

Although the sensors and recorded data will vary by model, the main data points are:

- Drive Unit status and Drive Unit performance data

This data will be uploaded only when a special Yamaha diagnostic tool is attached to the Drive Unit, such as when maintenance checks or service procedures are performed.

Yamaha will not disclose this data to a third party except in the following cases. In addition, Yamaha may provide Drive Unit data to a contractor in order to outsource services related to the handling of the Drive Unit data. Even in this case, Yamaha will require the contractor to properly handle the Drive Unit data we provided and Yamaha will appropriately manage the data.

- With the consent of the owner
- Where obligated by law
- For use by Yamaha in litigation
- For general Yamaha-conducted research purposes when the data is not related to an individual Drive Unit or owner

C. Location of the warning and specification labels

Read and understand all of the labels on your Battery Pack and Battery Charger. These labels contain important information for safe and proper operation. Never remove any labels from your Battery Pack and Battery Charger:

Battery Pack

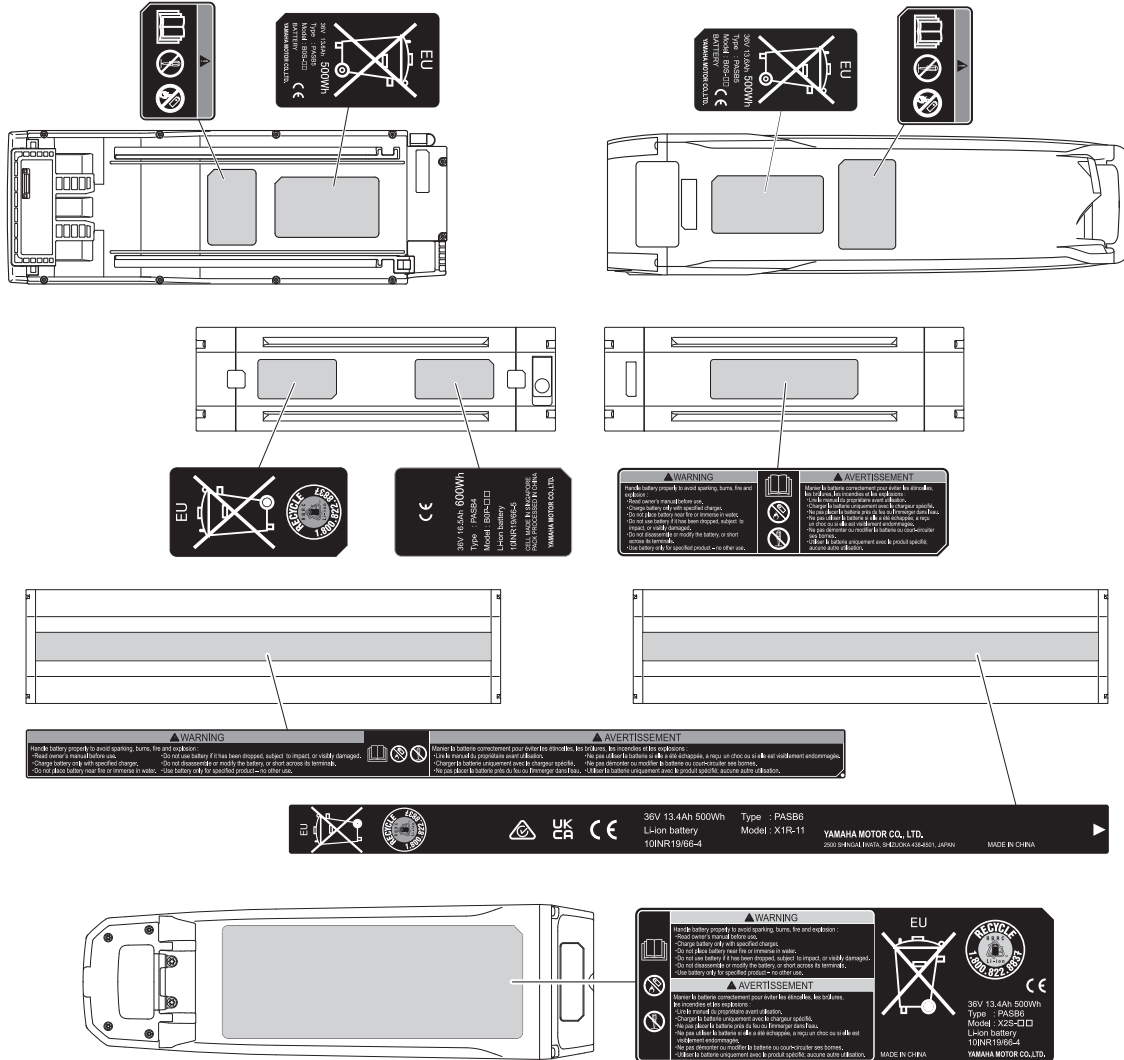

Battery Charger

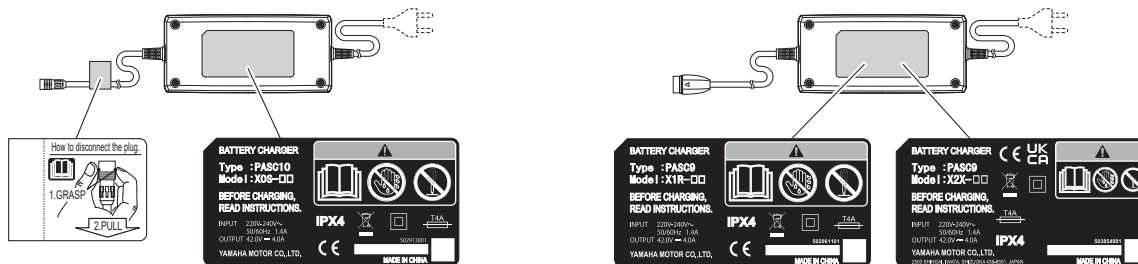

Familiarize yourself with the following pictograms and read the explanatory text, then make sure to check the pictograms that apply to your model.

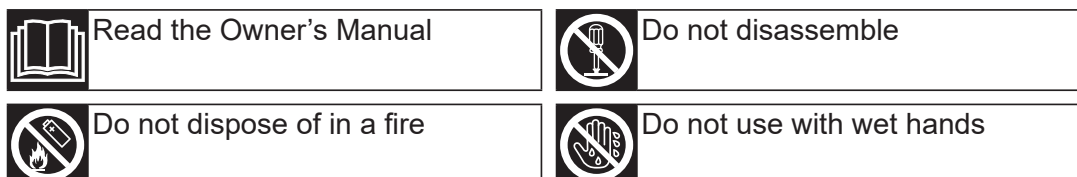

D. Description

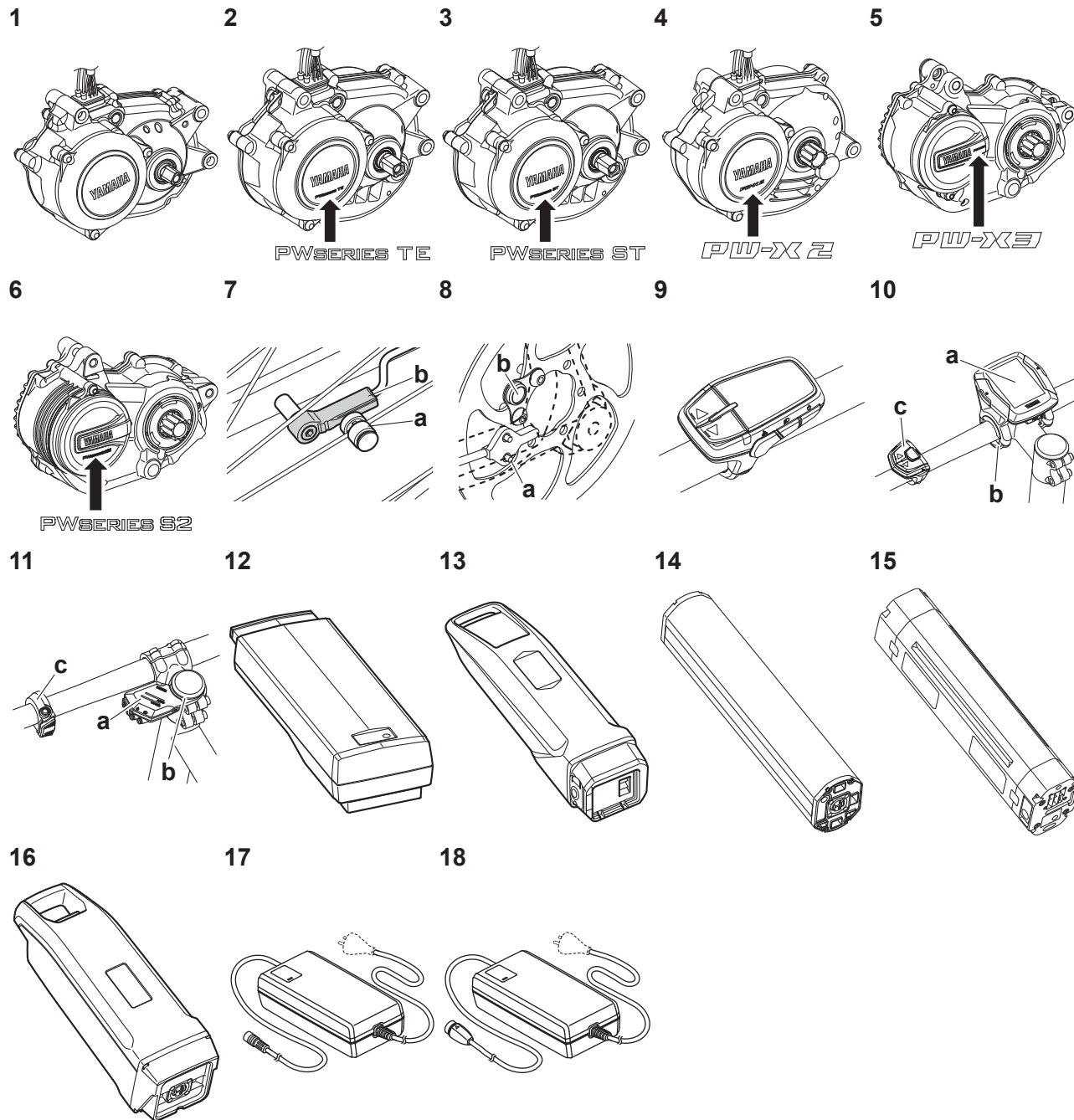

1. Drive Unit (PWseries CE)
2. Drive Unit (PWseries TE)
3. Drive Unit (PWseries ST)
4. Drive Unit (PW-X2)
5. Drive Unit (PW-X3)
6. Drive Unit (PWseries S2)
7. Speed Sensor Set
 - a) Spoke magnet
 - b) Speed sensor
8. Speed Sensor Set
 - a) Rotor magnet
 - b) Speed sensor
9. Display Unit (Display A)

10. Display Unit (Display C)
 - a) Display
 - b) Clamp
 - c) Remote switch
11. Display Unit (Interface X)
 - a) Communication unit
 - b) Mounting spacer
 - c) Remote switch
12. Battery Pack (Rear Carrier Battery 400/500)
13. Battery Pack (Down Tube Battery 400/500)
14. Battery Pack (Multi Location Battery 400/500)

15. Battery Pack (Multi Location Battery 600)
16. Battery Pack (External Crossover Battery 400/500)
17. Battery Charger (PASC10)
18. Battery Charger (PASC9)

E. e-Bike Systems

The e-Bike Systems are designed to give you the optimal amount of power assist.

It assists you within a standard range based on factors such as your pedaling strength, bicycle speed, and current gear.

The e-Bike Systems do not assist in the following situations:

- When the Display Unit's power is off.
- When you are moving 25 km/h or faster.
- When you are not pedaling.
- When walk assist is not operated.
- When there is no residual battery capacity.
- When the automatic power off function* works.
 - * Power turns off automatically when you do not operate the e-Bike Systems for 5 minutes.
- When the assist mode is set to Off Mode.
- When the language setting of Display C is executed.

Multiple power assist modes are available.

Choose from Extra Power Mode*¹, High-Performance Mode, Standard Mode, Eco Mode, +Eco Mode and Off Mode to suit your riding conditions.

See "Displaying and switching the assist mode" for information on switching between assist modes.

Assist mode	Display ^{*2}	Example of recommended driving environment
Extra Power Mode ^{*1}	EXPW	Use when climbing rough terrain.
High-Performance Mode	HIGH	Use when you want to ride more comfortably, such as when climbing a steep hill.
Standard Mode	STD	Use when riding on flat roads or climbing gentle hills.
Eco Mode	ECO	Use when you want to ride as far as possible.
+Eco Mode	+ECO	
Off Mode	OFF	Use when you want to ride without power assist. You can still use the other Display Unit functions.

^{*1} Applies to the Drive Unit (PW-X2, PW-X3).

^{*2} The Display Unit (Interface X) is displayed by the indicator.

Conditions that could decrease range (remaining assist distance)

The range (remaining assist distance) will decrease when riding in the following conditions:

- Frequent starts and stops
- Numerous steep inclines
- Poor road surface conditions
- When riding together with children
- Riding into a strong head wind
- Low air temperature
- Worn-out Battery Pack
- When using the headlight (applies only to models equipped with lights powered by the Battery Pack)
- Frequent acceleration
- Heavier rider and luggage weight
- Higher assist mode
- Higher riding speed

Range (Remaining assist distance) will also decrease if the bicycle is not maintained properly. Examples of inadequate maintenance that could decrease range (remaining assist distance):

- Low tire pressure
- Chain not turning smoothly
- Brake engaged constantly

F. ⚠ Safety information

Never use this Battery Charger to charge other electrical appliances.

Do not use any other charger or charging method to recharge the Battery Packs. Using any other charger could result in fire, explosion, or damage the Battery Packs.

This Battery Charger can be used by children aged from 8 years and above and persons with reduced physical, sensory or mental capabilities or lack of experience and knowledge if they have been given supervision or instruction concerning use of the Battery Charger in a safe way and understand the hazards involved. Children shall not play with the Battery Charger. Cleaning and user maintenance shall not be made by children without supervision.

Although the Battery Charger is waterproof, never allow it to become immersed in water or other fluids. In addition, never use the Battery Charger if the terminals are wet.

Never handle the power plug, charging plug or touch the Battery Charger contacts with wet hands. This could result in electric shock.

Do not touch Battery Charger contacts with metallic objects. Do not allow foreign material to cause short circuit of the contacts. This could result in electric shock, fire, or damage the Battery Charger.

Periodically remove dust from the power plug. Dampness or other issues could reduce the effectiveness of the insulation, resulting in fire.

Never disassemble or modify the Battery Charger. This could result in fire or electric shock.

Do not use with a power strip or extension cord. Using a power strip or similar methods may exceed rated current and can result in fire.

Do not use with the cable tied or rolled up, and do not store with the cable wrapped around the Battery Charger main body. Cable damage can result in fire or electric shock.

Firmly insert the power plug and the charging plug into the socket. Failure to insert the power plug and the charging plug completely can result in fire caused by electric shock or overheating.

Do not use the Battery Charger near flammable material or gas. This could result in fire or explosion.

Never cover the Battery Charger or place other objects on top of it while charging. This could result in internal overheating leading to fire.

Do not drop the Battery Charger or expose it to strong impacts. Otherwise, it could cause a fire or electric shock.

Store the Battery Pack and Battery Charger out of reach of children.

Do not touch the Battery Pack or Battery Charger while it is charging. As the Battery Pack or Battery Charger reaches 40–70 °C during charging, touching it could result in burns.

Do not use if the Battery Pack case is damaged, cracked, or if you smell any unusual odors. Leaking battery fluid can cause serious injury.

Do not short the contacts of the Battery Pack. Doing so could cause the Battery Pack to become hot or catch fire, resulting in serious injury or property damage.

Do not disassemble or modify the Battery Pack. Doing so could cause the Battery Pack to become hot or catch fire, resulting in serious injury or property damage.

If the power cable is damaged, stop using the Battery Charger and have it inspected at a bicycle dealer.

Do not turn the pedals or move the bicycle while the Battery Charger is connected. Doing so could cause the power cable to become tangled in the pedals, resulting in damage to the Battery Charger, power cable, and/or plug.

Handle the power cable with care. Connecting the Battery Charger from indoors while the bicycle is outdoors could result in the power cable becoming pinched and damaged in a doorway or window.

Do not run over the power cable or plug with the wheels of the bicycle. Doing so could result in damage to the power cable or plug.

Do not drop the Battery Pack or subject it to impact. Doing so could cause the Battery Pack to become hot or catch fire, resulting in serious injury or property damage.

Do not dispose of the Battery Pack in a fire or expose it to a heat source. Doing so could cause fire, or explosion, resulting in serious injury or property damage.

Do not modify or disassemble the e-Bike Systems. Do not install anything other than genuine parts and accessories. Doing so could result in product damage, malfunction, or increase your risk of injury.

When stopped, be sure to apply the front and rear brakes and keep both feet on the ground. Placing one's foot on the pedal when stopped may unintentionally engage the power assist function, which could result in loss of control and serious injury.

Do not ride the bicycle if there is any irregularity with the Battery Pack or e-Bike Systems. Doing so could lead to loss of control and serious injury.

Be sure to check the residual battery capacity before riding at night. The headlight powered by the Battery Pack will turn off soon after the residual battery capacity has decreased to where power assisted riding is no longer possible. Riding without an operating headlight can increase your risk of injury.

Do not start off by running with one foot on a pedal and one foot on the ground and then mounting the bicycle after it has reached a certain speed. Doing so could result in loss of control or serious injury. Be sure to start riding only after you are seated properly on the bicycle seat.

Do not use the walk assist if the rear tire is off the ground. Otherwise, the tire will turn at high speed in the air and you could be injured.

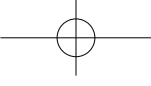

Do not use the wireless communication functions in areas such as hospitals or medical institutions where use of electronic equipment or wireless communication devices are prohibited. Otherwise, this could affect the medical equipment, etc. and cause an accident.

When using the wireless communication functions, keep the display at a safe distance from heart pacemakers in use. Otherwise, the radio waves could affect the heart pacemaker function.

Do not use the wireless communication functions near automatic control equipment such as automatic doors, fire alarms, etc. Otherwise, the radio waves could affect the equipment and cause an accident through possible malfunction or unintentional operation.

Before equipping the bicycle with a Multi Location Battery 400/500, make sure that there is no foreign matter or water in the connector on the bicycle. Otherwise, it could lead to heat generation, smoke and/or a fire owing to short-circuiting of the terminals.

For bicycles equipped with a Multi Location Battery 400/500, do not remove the Battery Pack from the bicycle when cleaning the bicycle. Otherwise, water could enter the connector and cause heat generation, smoke and/or a fire.

G. Instrument and control functions

Display Unit (Display A)

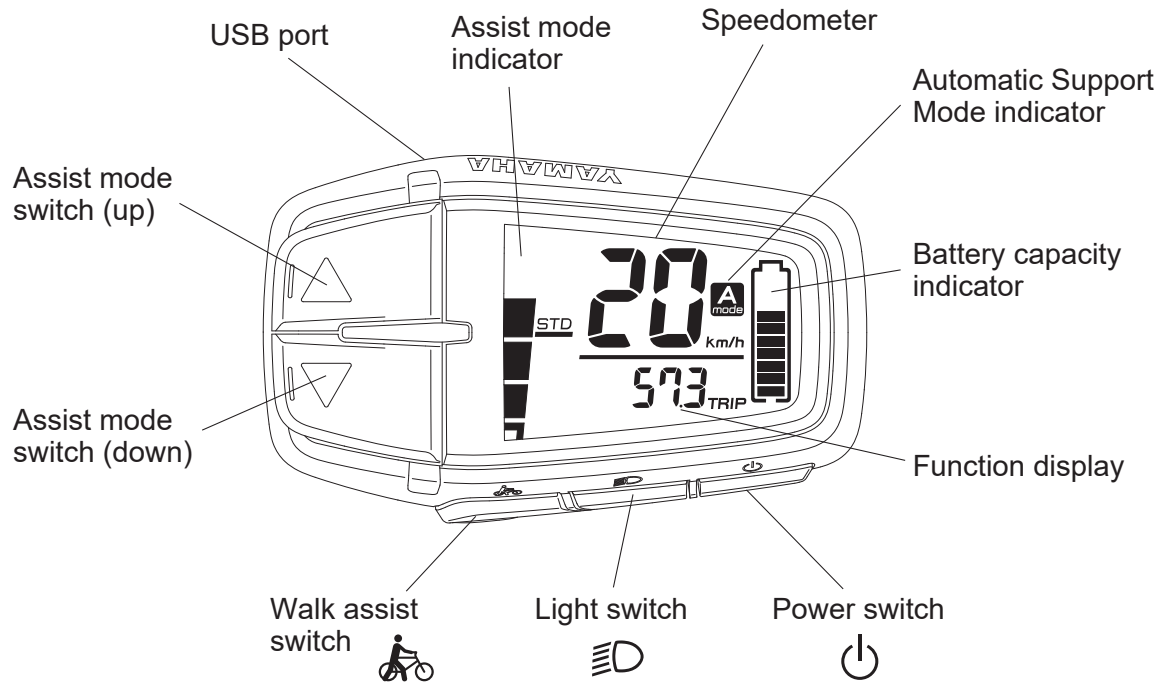

TIP

The USB port is for connecting the designated YAMAHA diagnostic tool; it cannot be used as a power supply.

Display Unit (Display A)

The Display Unit offers the following operations and information displays.

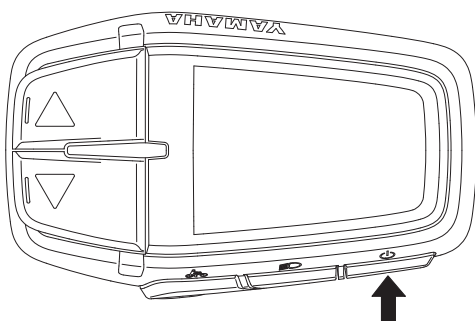
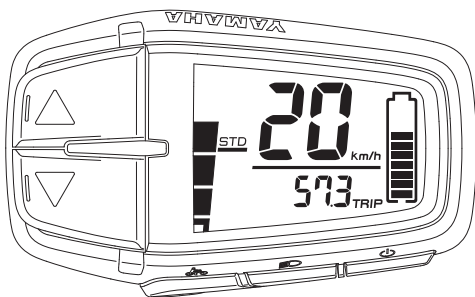

○ Power on/off

Each time you press the power switch, the power is turned on and off.

When you turn on the power, all of the displays come up. After that, the main riding display is shown.

TIP

Keep your feet off the pedals when turning on the Display Unit. Also, do not start riding immediately after turning on the Display Unit. Doing so could weaken the assist power. (Weak assist power in either of these cases is not a malfunction.) If you did either of the above by accident, remove your feet from the pedals, turn on the power again, and wait a moment (approximately two seconds) before starting to ride.

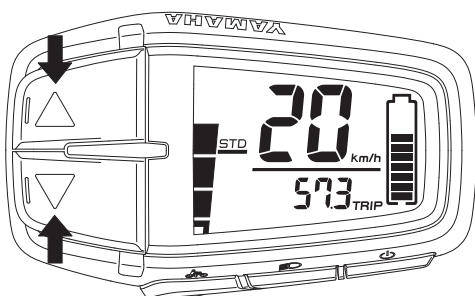

○ Displaying and switching the assist mode

You can select the assist mode by using the assist mode switches (up) or (down).

The selected assist mode is displayed by the assist mode indicator.

- When you press the assist mode switch (up), the mode changes from “OFF” to “+ECO”, or from “+ECO” to “ECO”, or “ECO” to “STD”, or “STD” to “HIGH”, or “HIGH” to “EXPW”.
- When you press the assist mode switch (down), the mode changes from “EXPW” to “HIGH”, or from “HIGH” to “STD”, or “STD” to “ECO”, or “ECO” to “+ECO”, or “+ECO” to “OFF”.

TIP

- Bicycles equipped with the PWseries CE, PWseries TE, PWseries ST, or PWseries S2 Drive Unit have no Extra Power Mode.
- Further pressing of the assist mode switch will not cycle the assist mode selections.
- When the power is turned on, the e-Bike Systems will be activated with the same assist mode as when the power was last turned off.

The Automatic Support Mode, which enables automatic change to the optimal assist mode according to the riding conditions, can also be used.

- To use the Automatic Support Mode, press the assist mode switch (up) for 1 second or longer. The Automatic Support Mode indicator will light up and the mode will be changed to the Automatic Support Mode.
- To cancel the Automatic Support Mode, press the assist mode switch (up) for 1 second or longer. The Automatic Support Mode indicator will go off and the Automatic Support Mode will be canceled.

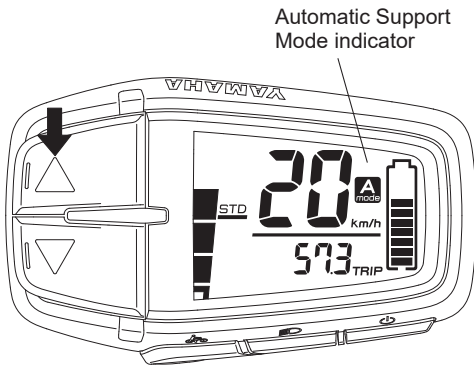

TIP

- Even if you press the assist mode switches (up) or (down) while in Automatic Support Mode, the assist mode cannot be changed.
- The Automatic Support Mode is saved when the power is turned off. When you turn on the power again, the e-Bike Systems will be activated with the Automatic Support Mode.

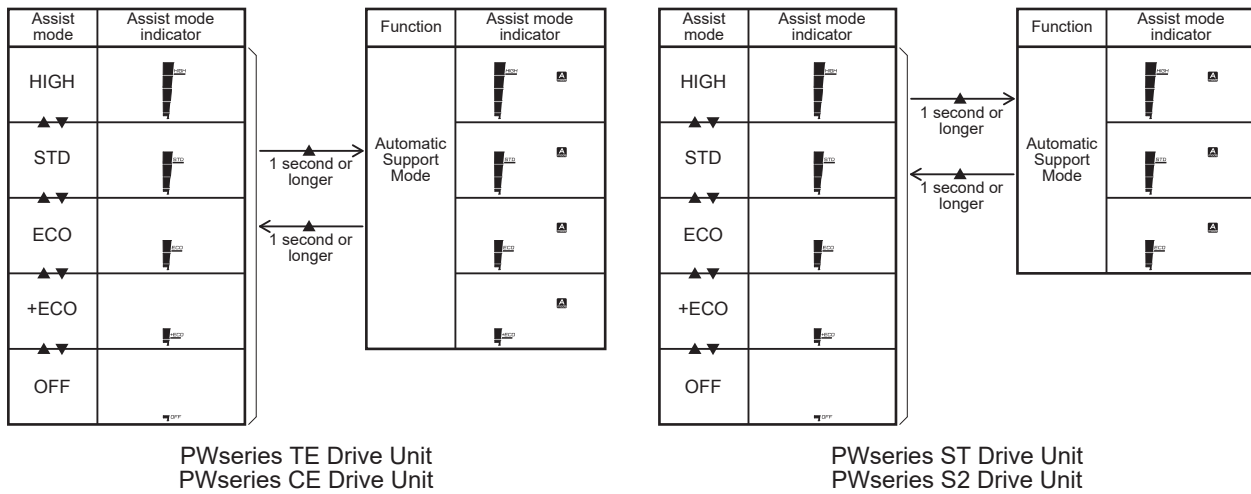

PWseries TE Drive Unit
PWseries CE Drive Unit

PWseries ST Drive Unit
PWseries S2 Drive Unit

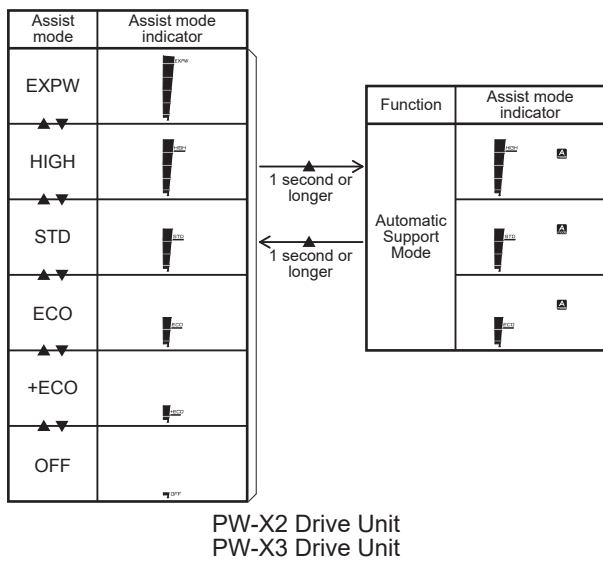

PW-X2 Drive Unit
PW-X3 Drive Unit

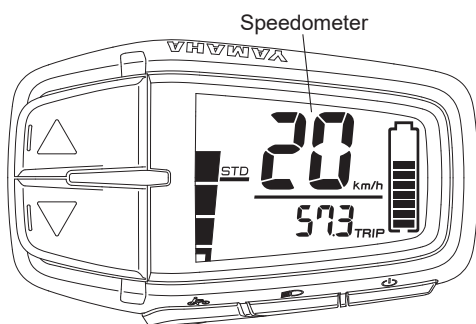

○ Speedometer

The speedometer displays your bicycle speed (in kilometer per hour or mile per hour). To select the km/mile, see “km/mile setting”.

TIP

If your bicycle speed is less than 2.0 km/h or 1.2 MPH, the speedometer displays “0 km/h” or “0 MPH”.

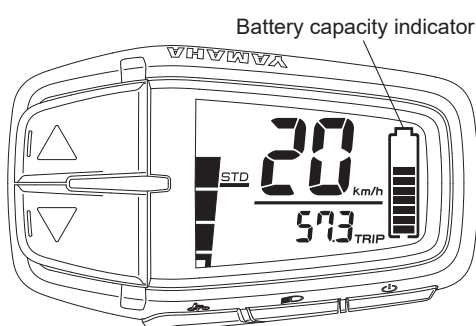

○ Battery capacity indicator

The battery capacity indicator displays an estimate of how much capacity is left in the Battery Pack.

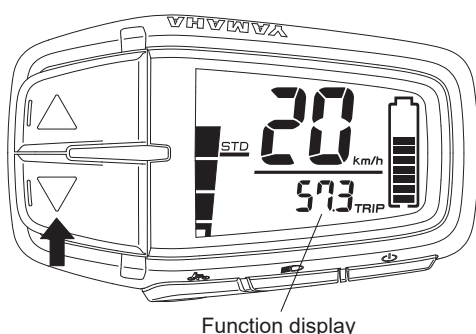

○ Function display

The function display can display the following functions.

- Odometer
- Trip meter
- Range (Remaining assist distance)

Push the assist mode switch (down) for 1 second or longer, the display changes as follows:

Odometer → Trip meter → Range → Odometer

You can reset the data for trip meter.

● Odometer

This displays the total distance (in kilometers or miles) ridden while the power was on.

The odometer cannot be reset.

● Trip meter

This displays the total riding distance (in kilometers or miles) since it was last reset.

When you turn off the power, the data up to that point will be saved.

To reset the trip meter and begin counting a new total, press the assist mode switch (up) and assist mode switch (down) simultaneously for 2 seconds or longer when the trip meter is displayed.

157^{ODO}

33.1^{TRIP}

86
RANGE

● Range (Remaining assist distance)

This displays an estimate of the distance (in kilometers or miles) that can be ridden with assist on the residual battery capacity of the Battery Pack installed. If you switch the assist mode when the range (remaining assist distance) is displayed, the estimate of the distance that can be ridden with assist changes.

The range (remaining assist distance) estimate cannot be reset.

TIP

- Actual range (remaining assist distance) changes depending on the riding situation (hills, headwind, etc.) and as the Battery Pack runs down.
- If in Off Mode, “- - -” is displayed.

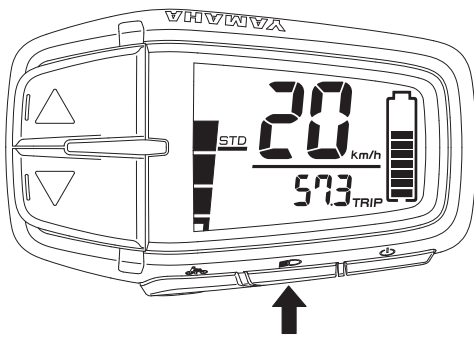

○ Headlight on/off

For models equipped with a headlight or taillight powered by the Battery Pack, each time you press the light switch, the headlight and taillight will turn on and off.

TIP

When the power is turned on, the lights will return to the last on/off setting.

○ km/mile setting

Use the following steps to set the km/mile setting.

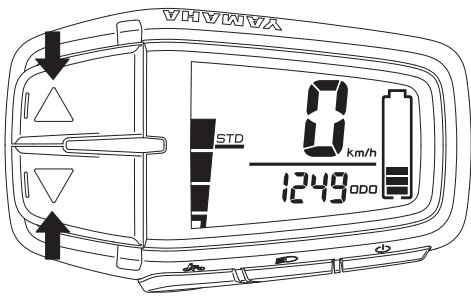

1. Make sure that the Display Unit is turned on.
2. Select the odometer display in the function display.
3. Press the assist mode switch (up) and assist mode switch (down) simultaneously for 2 seconds or longer.
4. When either “km/h” or “MPH” flashes, release the switch.
5. Use the assist mode switches (up) or (down) to set either the km or mile unit.
6. While the unit that you want to set is flashing, press the assist mode switch (down) for 1 second or longer, and release the switch when the display returns to the main riding display.

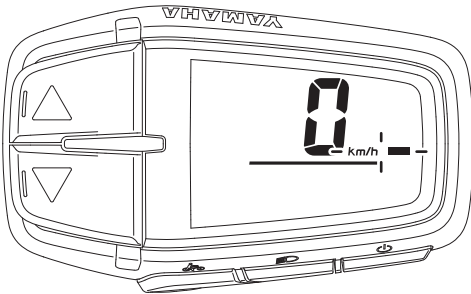

! WARNING

For all setting procedures, be sure to stop the bicycle and perform the required settings in a safe location. Otherwise, lack of attention to surrounding traffic or other hazards could cause an accident.

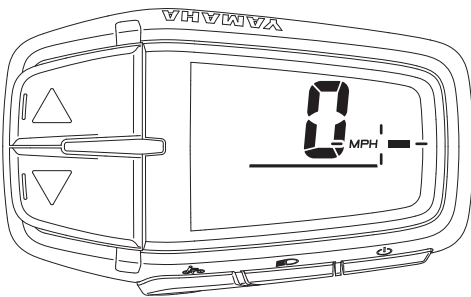

TIP

- The settings cannot be adjusted while riding.
- If you do the following during setting, the item that you are setting will be canceled and the display will return to the main riding display.
 - Turning the crank (pedal) in the traveling direction
 - Turning the rear wheel at 2 km/h and more
 - Pushing the walk assist switch

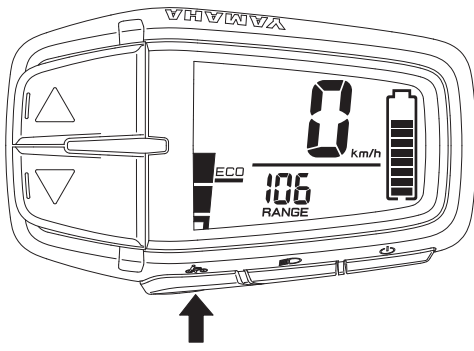

○ Walk assist

When you are on or off the bicycle and start moving it, you can use walk assist without pedaling the bicycle.

To use walk assist, press and hold the walk assist switch.

Walk assist will not work in the following situations:

- When you release the walk assist switch.
- If you press another switch at the same time.
- When you start to pedal.
- If your bicycle speed exceeds 6 km/h.
- If you select Off Mode.
- If the wheels are not turning (when braking or coming into contact with an obstacle, etc.).

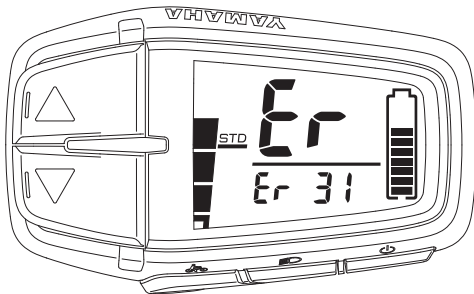
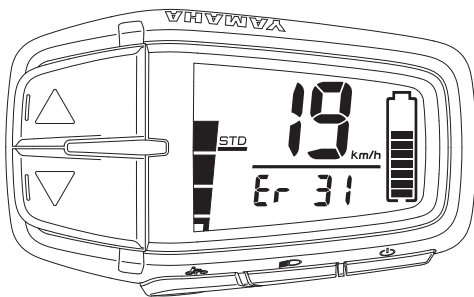

○ Self-diagnosis function

The e-Bike Systems are equipped with a self-diagnosis function.

If a malfunction or fault occurs in the e-Bike Systems, the main riding display and “Er” will be shown alternately, while an error code will inform you of the type of error in the function display. See “Troubleshooting” regarding symptoms and remedies for abnormal displays and abnormal flashing.

WARNING

If the problem cannot be solved, have your bicycle inspected by a dealer as soon as possible.

Display Unit (Display C)

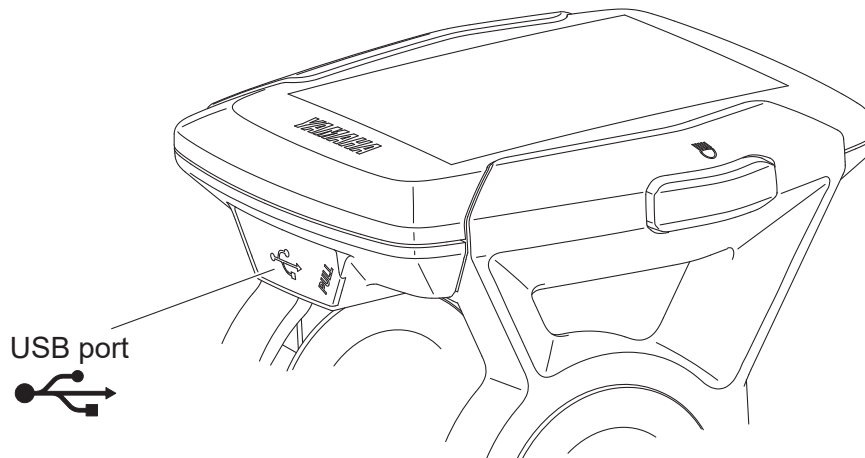
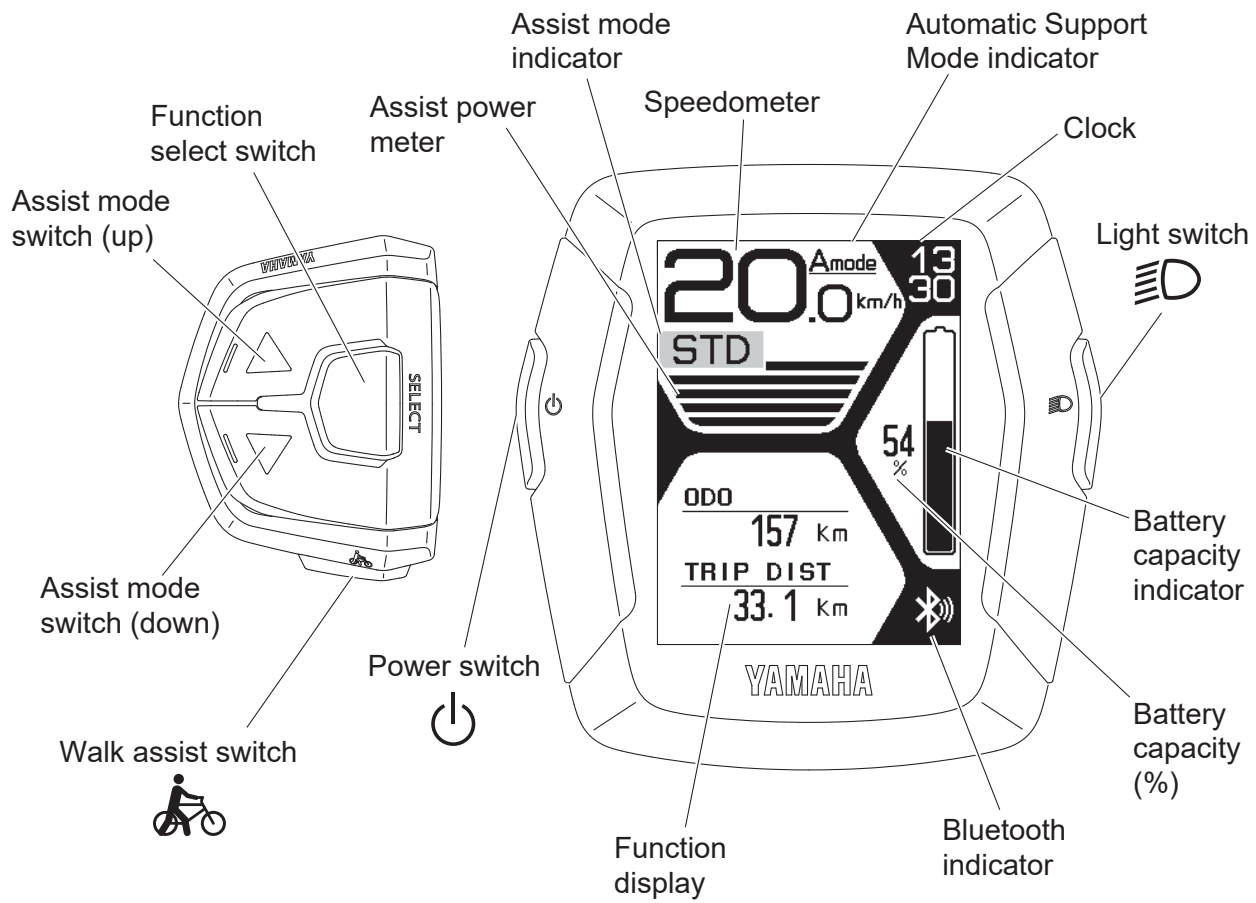

Display Unit (Display C)

The Display Unit offers the following operations and information displays.

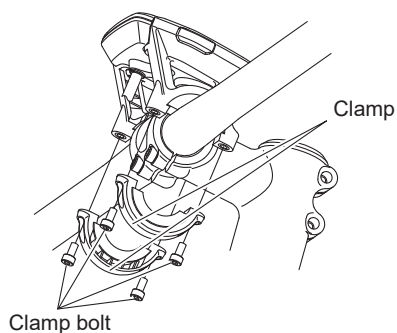
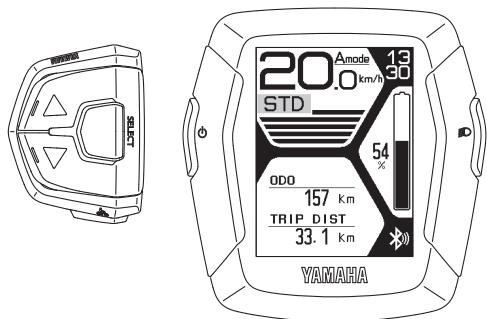

○ Installing the coin battery (CR2032)

The Display Unit needs to be removed and installed for changing the coin battery.

- Remove the clamp by loosening the four bolts and remove the display from the handle.
- When installing the Display Unit, tighten the four clamp bolts from the back side of the clamp.

⚠ WARNING

Tighten the clamp bolts to 2 N·m. Otherwise, during riding, vibration could cause the clamp bolts to come loose with the risk that the Display Unit may fall off. A loose display could distract the rider or interfere with control and cause an accident.

○ Coin battery (CR2032)

Check if the rated coin battery is installed in the rear of the Display Unit.

If a coin battery is not installed, or if there is not sufficient battery power remaining, install a new coin battery.

After installing a new coin battery, turn the power on once and then off so that the Display Unit can recognize the coin battery.

In case of setting the language, see “Language”.

To adjust the time, see “Settings”.

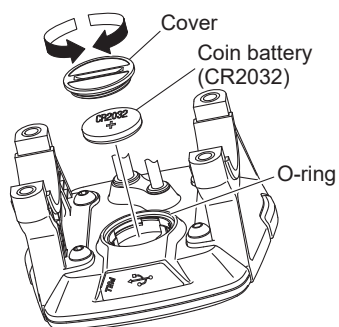

**WARNING**

Coin battery is hazardous and is to be kept away from children (whether the battery is new or used).

If the cover of coin battery does not close securely, stop using the product.

Coin battery can cause severe or fatal injuries in 2 hours or less if it is swallowed or placed inside any part of the body.

Medical attention should be sought immediately if it is suspected coin battery has been swallowed or placed inside any part of the body.

Unfortunately, it is not obvious when coin battery is stuck in a child's oesophagus (food pipe).

There are no specific symptoms associated with this.

The child might:

- cough, gag or drool a lot;
- appear to have a stomach upset or a virus;
- be sick;
- point to their throat or stomach;
- have a pain in their abdomen, chest or throat;
- be tired or lethargic;
- be quieter or more clingy than usual or otherwise "not themselves";
- lose their appetite or have a reduced appetite; and
- not want to eat solid food/be unable to eat solid food.

These sorts of symptoms vary or fluctuate, with the pain increasing and then subsiding.

A specific symptom to coin battery ingestion is vomiting fresh (bright red) blood. If the child does this seek immediate medical help.

The lack of clear symptoms is why it is important to be vigilant with used or spare coin batteries in the home and the products that contain them.

TIP

- Make sure that the O-ring is installed correctly.
 - Use a new coin battery (sold separately).
 - When a coin battery is drained, whenever the vehicle power supply is turned on, 11:00 appears and it disappears approximately 10 seconds later. Additionally the language indication is in English. Replace the coin battery if this happens.
-

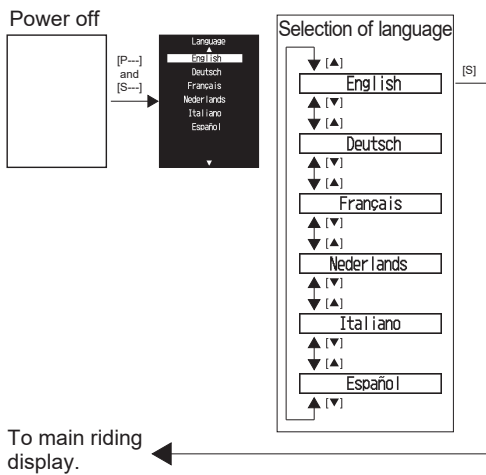
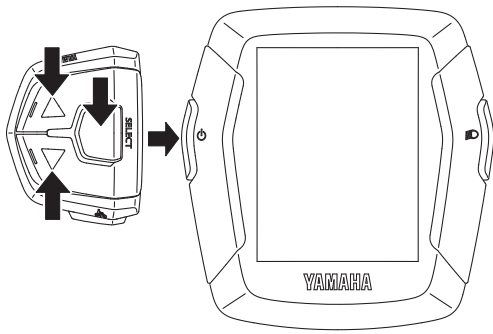

○ Language

In Display C, you can select the language between the following languages:

SUPPORTED LANGUAGE	DISPLAY
English	English
German	Deutsch
French	Français
Dutch	Nederlands
Italian	Italiano
Spanish	Español

1. Make sure that the power is turned off.
When nothing is shown in the display, the power is off. When something is shown in the display, the power is on. Press the power switch to turn the power off.
2. Hold the power switch and function select switch pressed simultaneously for 2 seconds or longer.
3. Select the language by using the assist mode switches (up) or (down), and then press the function select switch. This setting will then be kept and the display will return to the main riding display.

⚠ WARNING

When setting the language, be sure to stop the bicycle and to set the language in a safe location. Otherwise, lack of attention to surrounding traffic or other hazards could cause an accident.

TIP

- If a coin battery (CR2032) is not installed, or if the remaining battery power is insufficient, “Requires CR2032” is shown in the display. Even if you set the language in this situation, the display will return to the English setting each time the power is turned off. Install the coin battery or replace the coin battery to set the language.
- After installing the coin battery, “Requires CR2032” may still be shown in the display. In that case, turn the power off once.
- The assist system does not function while setting the language.

[P---] …… Press the power switch for 2 seconds or longer
[S---] …… Press the function select switch for 2 seconds or longer

[S] …… Press the function select switch

[▲] …… Press the assist mode switch (up)

[▼] …… Press the assist mode switch (down)

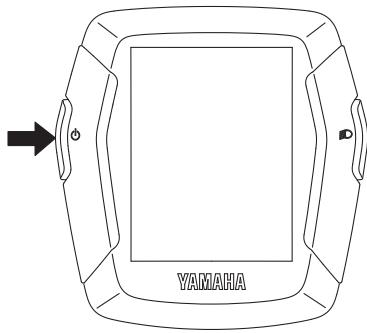

○ Power on/off

Each time you press the power switch, the power is turned on and off.

When you turn on the power, the animation will be displayed.

After that, the main riding display is shown.

TIP

Keep your feet off the pedals when turning on the Display Unit. Also, do not start riding immediately after turning on the Display Unit. Doing so could weaken the assist power. (Weak assist power in either of these cases is not a malfunction.) If you did either of the above by accident, remove your feet from the pedals, turn on the power again, and wait a moment (approximately two seconds) before starting to ride.

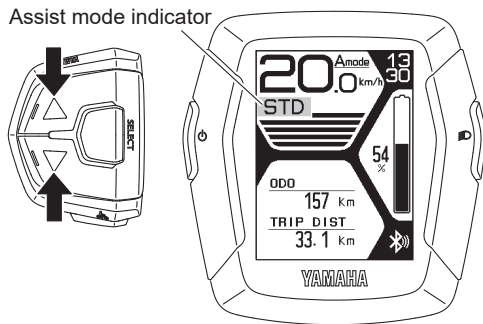

○ Displaying and switching the assist mode

You can select the assist mode by using the assist mode switches (up) or (down).

The selected assist mode is displayed by the assist mode indicator.

- When you press the assist mode switch (up), the mode changes from “OFF” to “+ECO”, or from “+ECO” to “ECO”, or “ECO” to “STD”, or “STD” to “HIGH”, or “HIGH” to “EXPW”.
- When you press the assist mode switch (down), the mode changes from “EXPW” to “HIGH”, or from “HIGH” to “STD”, or “STD” to “ECO”, or “ECO” to “+ECO”, or “+ECO” to “OFF”.

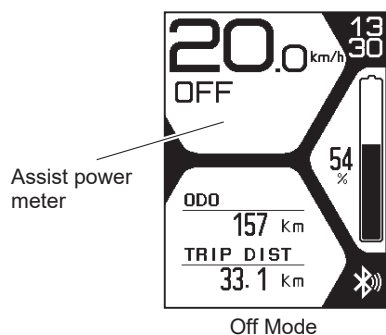

TIP

- Bicycles equipped with the PWseries CE, PWseries TE, PWseries ST, or PWseries S2 Drive Unit have no Extra Power Mode.
- Further pressing of the assist mode switch will not cycle the assist mode selections.
- In the Off Mode, the assist power meter is not displayed.
- When the power is turned on, the e-Bike Systems will be activated with the same assist mode as when the power was last turned off.

The Automatic Support Mode, which enables automatic change to the optimal assist mode according to the riding conditions, can also be used.

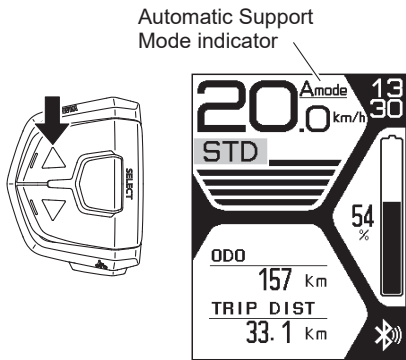

- To use the Automatic Support Mode, press the assist mode switch (up) for 1 second or longer. The Automatic Support Mode indicator will light up and the mode will be changed to the Automatic Support Mode.
- To cancel the Automatic Support Mode, press the assist mode switch (up) for 1 second or longer. The Automatic Support Mode indicator will go off and the Automatic Support Mode will be canceled.

TIP

- Even if you press the assist mode switches (up) or (down) while in Automatic Support Mode, the assist mode cannot be changed.
- The Automatic Support Mode is saved when the power is turned off. When you turn on the power again, the e-Bike Systems will be activated with the Automatic Support Mode.

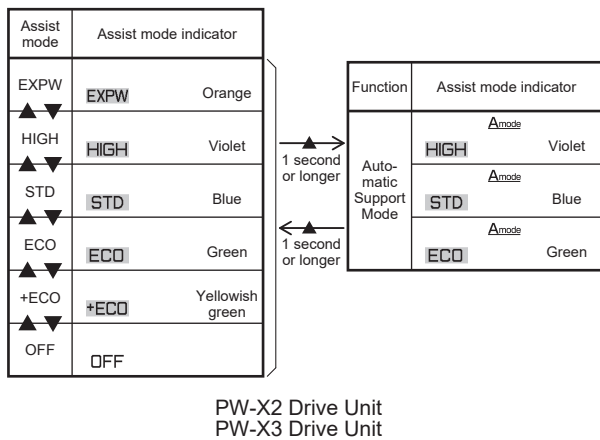
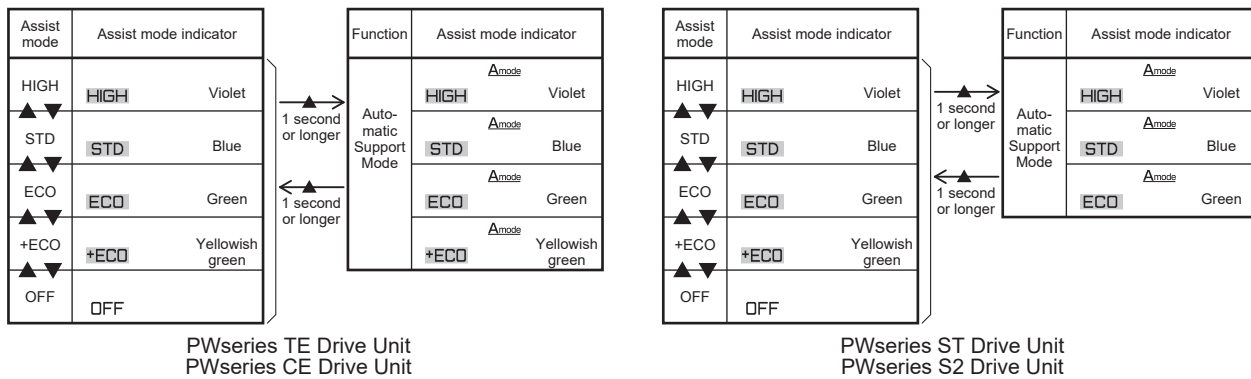

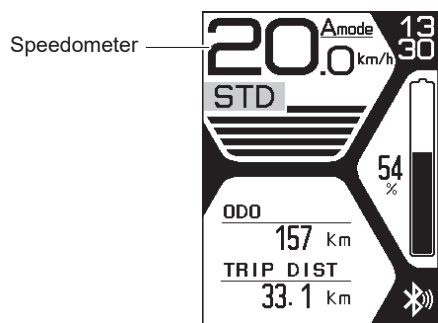

○ Speedometer

The speedometer displays your bicycle speed (in kilometer per hour or mile per hour). To select the km/mile, see “Settings”.

TIP

If your bicycle speed is less than 2.0 km/h or 1.2 MPH, the speedometer displays “0.0 km/h” or “0.0 MPH”.

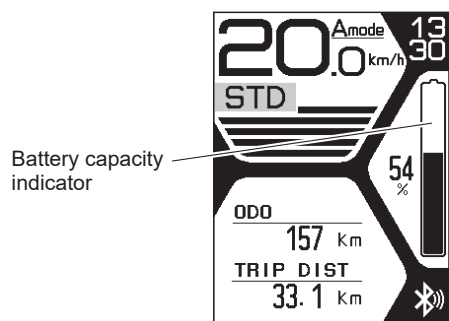

○ Battery capacity indicator

The battery capacity indicator displays an estimate of how much capacity is left in the Battery Pack.

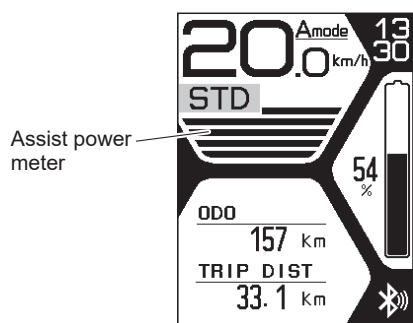

○ Assist power meter

The assist power meter displays an estimate of the assist power during riding.

When the e-Bike Systems are not in operation, none of the segments of the assist power meter are displayed. When the e-Bike Systems are operating, as the assist power increases, the segments of the assist power meter are added one by one.

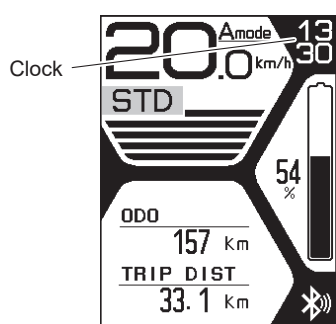

○ Clock

Displays the current time in 24 hour format. The upper part shows the “Hour” and the lower part the “Minute”. To adjust the time, see “Settings”.

TIP

- If a coin battery (CR2032) is not installed, or if the remaining battery power is insufficient, whenever the vehicle power supply is turned on, 11:00 appears and it disappears approximately 10 seconds later. Install the coin battery or replace the coin battery to adjust the clock.
- If the clock is not adjusted after the coin battery is installed or replaced, 00:00 will continue to appear.

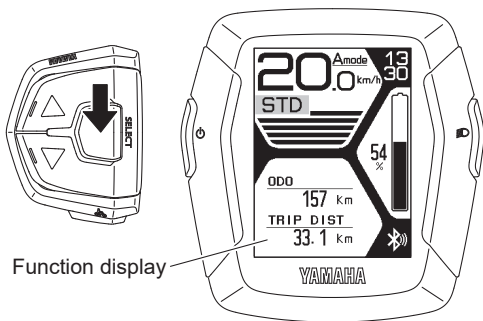

○ Function display

The function display can display the following functions.

- Odometer
- Trip meter
- Average bicycle speed
- Maximum bicycle speed
- Range (Remaining assist distance)
- Cadence
- Trip time

Push the function select switch, the display changes as follows:

Odometer → Trip meter → Average bicycle speed → Maximum bicycle speed → Range → Cadence → Trip time → Odometer

You can select the items to be displayed.

For more information, see “Settings”.

You can reset the data for trip meter, average bicycle speed, maximum bicycle speed, and trip time.

For more information, see “Settings”.

TIP

When you connect to the smartphone and run the application, the Trip meter, Trip time, Average bicycle speed, and Maximum bicycle speed will all be reset.

ODO
157 Km

TRIP DIST
33.1 Km

● Odometer

This displays the total distance (in kilometers or miles) ridden while the power was on.

The odometer cannot be reset.

● Trip meter

This displays the total riding distance (in kilometers or miles) since it was last reset.

When you turn off the power, the data up to that point will be saved.

To reset the trip meter and begin counting a new total, press the assist mode switch (up) and assist mode switch (down) simultaneously for 2 seconds or longer when the trip meter is displayed on the upper row of the function display. Or see “Settings”.

AVE
7.7 km/h

MAX
13.7 km/h

RANGE
15 km

CADENCE
50 rpm

● Average bicycle speed

This displays the average bicycle speed (in kilometers per hour or miles per hour) since it was last reset.

When you turn off the power, the data up to that point will be saved.

To reset the average bicycle speed, press the assist mode switch (up) and assist mode switch (down) simultaneously for 2 seconds or longer when the average bicycle speed is displayed on the upper row of the function display. Or see "Settings".

● Maximum bicycle speed

This displays the maximum bicycle speed (in kilometers per hour or miles per hour) since it was last reset.

When you turn off the power, the data up to that point will be saved.

To reset the maximum bicycle speed, press the assist mode switch (up) and assist mode switch (down) simultaneously for 2 seconds or longer when the maximum bicycle speed is displayed on the upper row of the function display. Or see "Settings".

● Range (Remaining assist distance)

This displays an estimate of the distance (in kilometers or miles) that can be ridden with assist on the residual battery capacity of the Battery Pack installed. If you switch the assist mode when the range (remaining assist distance) is displayed, the estimate of the distance that can be ridden with assist changes.

The range (remaining assist distance) estimate cannot be reset.

TIP

- Actual range (remaining assist distance) changes depending on the riding situation (hills, headwind, etc.) and as the Battery Pack runs down.
- If in Off Mode, "- - -" is displayed.

● Cadence

This displays your pedaling speed in revolutions per minute.

The pedaling cadence display cannot be reset.

TIP

If you pedal backwards, "0" is displayed.

TRIP TIME
1:47:35



● Trip time

This displays the total riding time since it was last reset. When you turn off the power, the data up to that point will be saved.

To reset the trip time, press the assist mode switch (up) and assist mode switch (down) simultaneously for 2 seconds or longer when the trip time is displayed on the function display. Or see “Settings”.

TIP

If your bicycle speed is less than 2.0 km/h or 1.2 MPH, the trip time will not be accumulated.

○ Headlight on/off

For models equipped with a headlight or taillight powered by the Battery Pack, each time you press the light switch, the headlight and taillight will turn on and off.

TIP

- Display backlight operates simultaneously with the light switch.
- As the light switch is turned on or off, the display backlight will light accordingly. For the procedure of selecting the brightness condition, see “Settings”.
- When the power is turned on, the lights will return to the last on/off setting.

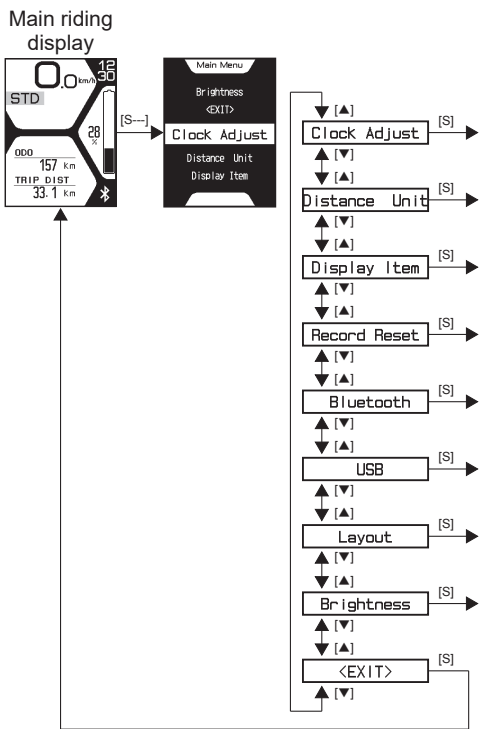
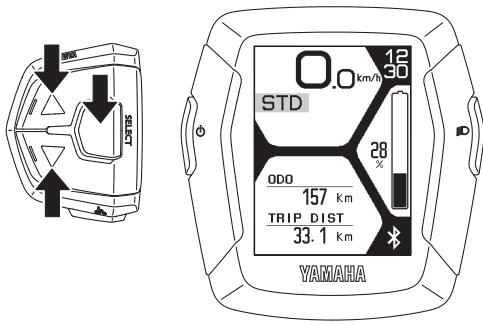

○ Settings

The display enables the following.

- Clock Adjust
Clock setting
- Distance Unit
km/mile setting
- Display Item
Sets the items to be displayed in the function display during normal riding.
- Record Reset
Resets the values of the trip meter, average bicycle speed, maximum bicycle speed, and trip time.
- Bluetooth (Bluetooth low energy technology)
Switches the profiles and turns off the wireless communication function.
- USB
Switches the USB port between a power supply port and a wired communication port.
- Layout
Switches the layout of the display.
- Brightness
Set the brightness and the color of the display backlight.

1. Press the function select switch for 2 seconds or longer.
2. Select an item by using the assist mode switches (up) or (down).
When you select an item to set and press the function select switch, the setting will be displayed.
Selecting “EXIT” returns to the main riding display.

⚠ WARNING

For all setting procedures, be sure to stop the bicycle and perform the required settings in a safe location. Otherwise, lack of attention to surrounding traffic or other hazards could cause an accident.

TIP

- The settings cannot be adjusted while riding.
- If you do the following during setting, the item that you are setting will be canceled and the display will return to the main riding display.
 - Turning the crank (pedal) in the traveling direction
 - Turning the rear wheel at 2 km/h and more
 - Pushing the walk assist switch

[S---]…… Press the function select switch for 2 seconds or longer

[S]…… Press the function select switch

[▲]…… Press the assist mode switch (up)

[▼]…… Press the assist mode switch (down)

● Clock Adjust

You can adjust the time of the clock.

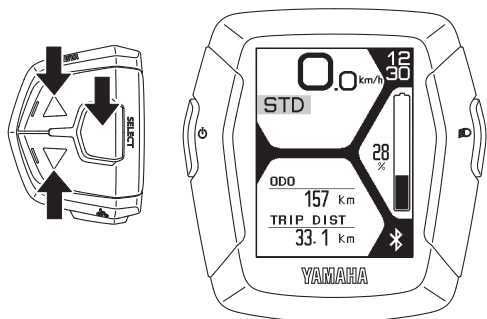

1. Check that the “Hour” is flashing and adjust the hour by using the assist mode switches (up) or (down).
2. Press the function select switch to adjust the minutes.
3. Check that the “Minute” is flashing and adjust the minutes by using the assist mode switches (up) or (down).
4. Press the function select switch to return to the Main Menu display.

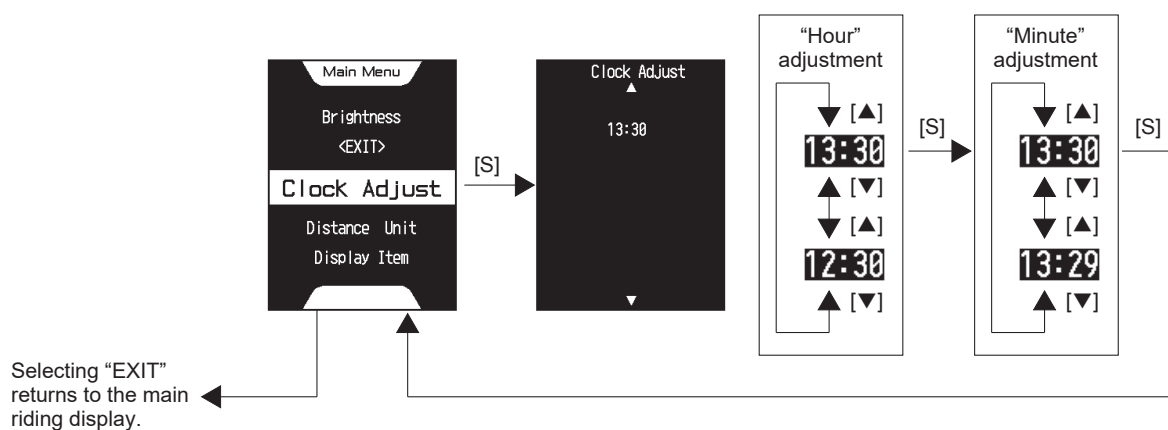

TIP

- If a coin battery (CR2032) is not installed, “Requires CR2032” is shown in the display.
- After installing the coin battery, “Requires CR2032” may still be shown in the display. In that case, turn the power off.

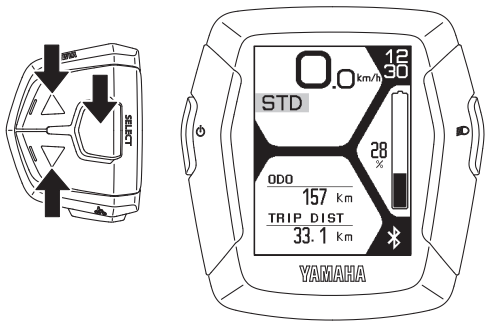

● Distance Unit

You can select the unit for distance and speed.

When “km” is selected, the traveled distance will be indicated in kilometers and the speed in km/h.

When “mile” is selected, the traveled distance will be indicated in miles and the speed in mph.

1. Select “km” or “mile” by using the assist mode switches (up) or (down).
2. When you press the function select switch, the setting will then be kept and the display will return to the Main Menu display.

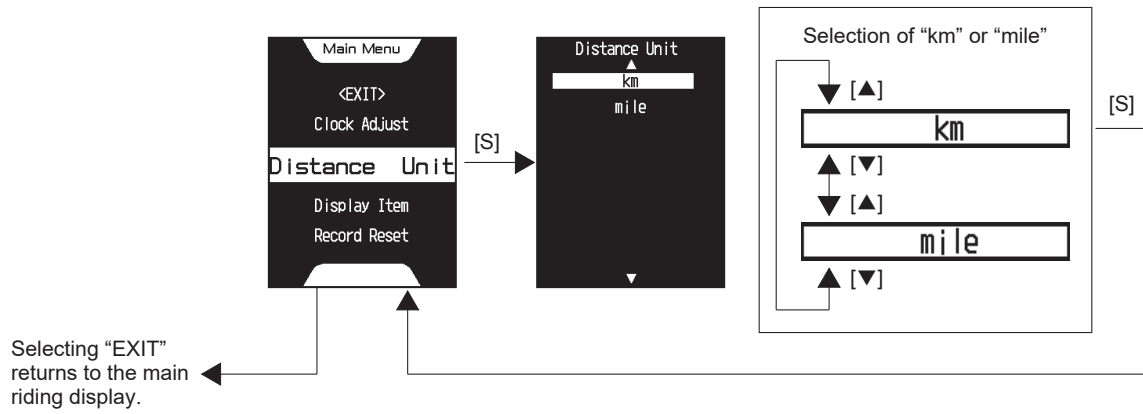

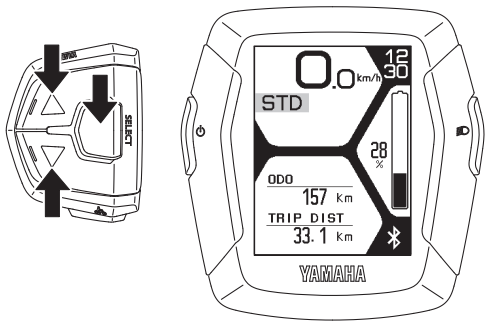

● Display Item

You can select to show or hide different items in the function display during normal riding.

The items which you can select to show or hide are: “Trip Distance” (Trip meter), “Average Speed” (Average bicycle speed), “Maximum Speed” (Maximum bicycle speed), “Battery Range” (Range), “Cadence”, and “Trip Time”.

TIP

You cannot hide the odometer indication.

1. Select an item by using the assist mode switches (up) or (down).
2. Use the function select switch to show or hide the selected item. (When an item is shown, a check mark will be shown in the check box.)
3. When you select “EXIT” and press the function select switch, the setting will be kept and the display will return to the Main Menu display.

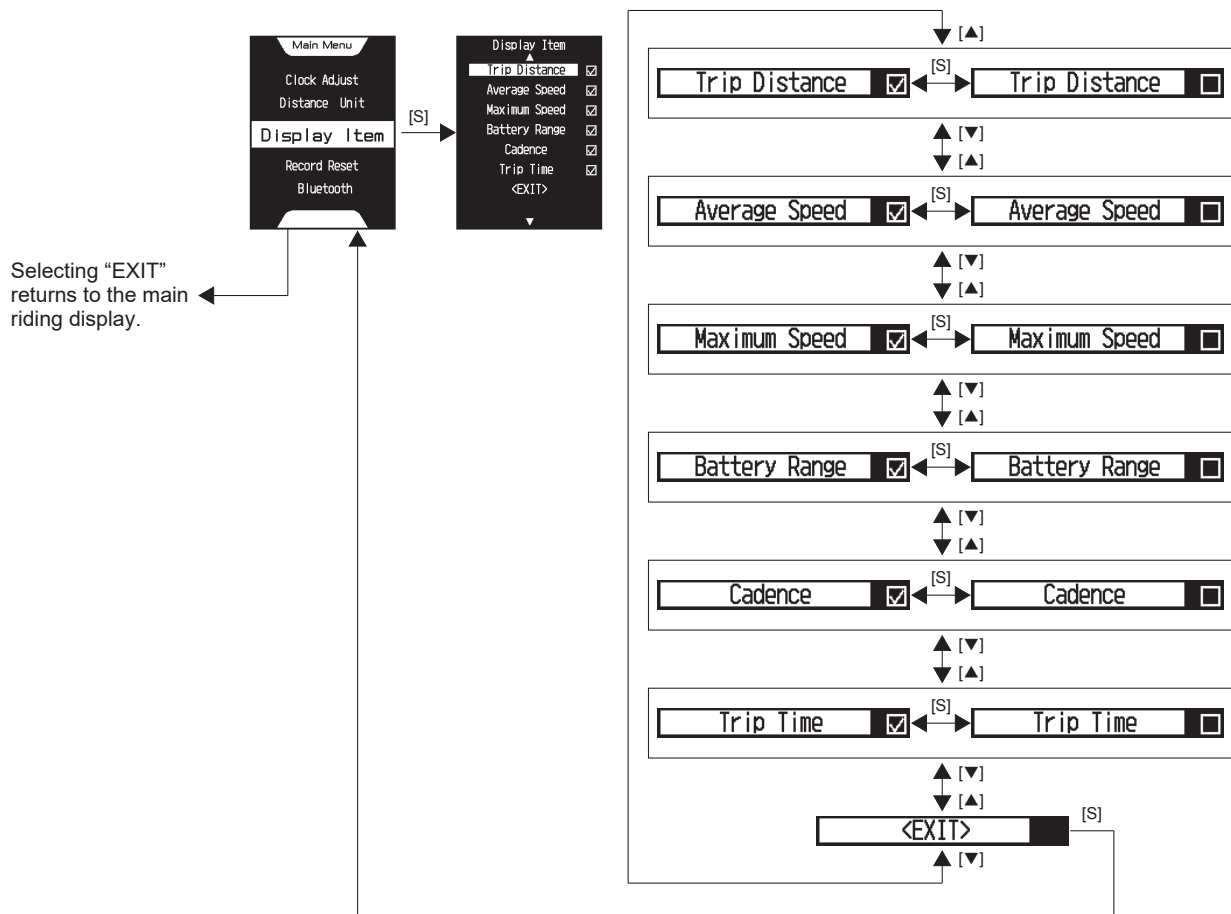

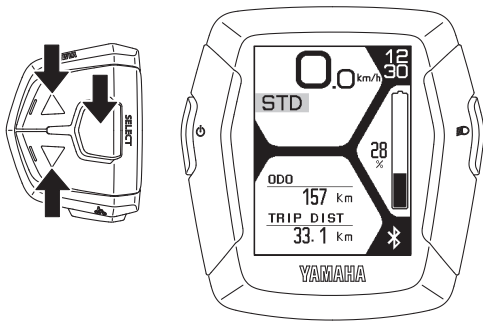

● Record Reset

You can reset the “Trip Distance” (Trip meter), “Average Speed” (Average bicycle speed), “Maximum Speed” (Maximum bicycle speed), and “Trip Time” values.

TIP

- You cannot reset the odometer.
- To reset the accumulated energy that is displayed on the device connected via the Bluetooth low energy technology, select either “CPP” or “YEP1.0” on the “Bluetooth” (Bluetooth low energy technology) display. “Total Calorie” will be added in the “Record Reset” display. Then, select “Total Calorie” to reset the accumulated energy.

1. Select an item by using the assist mode switches (up) or (down) and use the function select switch to place a check mark in the check box for the item that you want to reset.
2. When you select “EXIT” and press the function select switch, the items with check marks will be reset and the display will return to the Main Menu display.

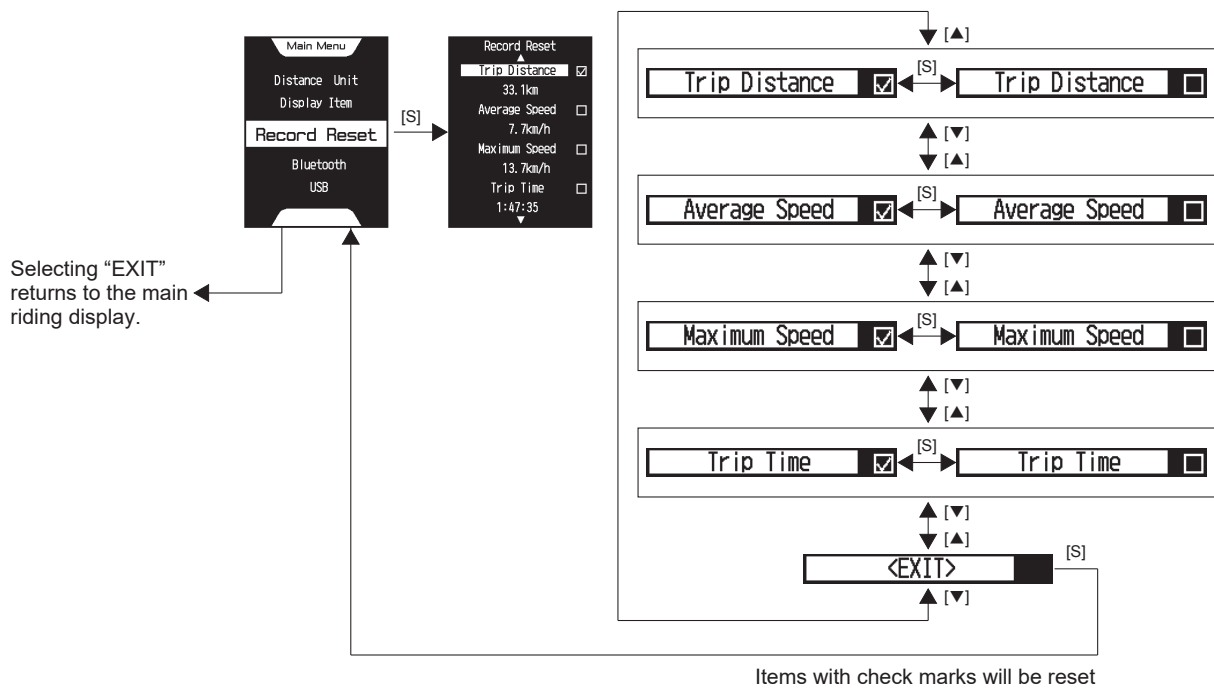

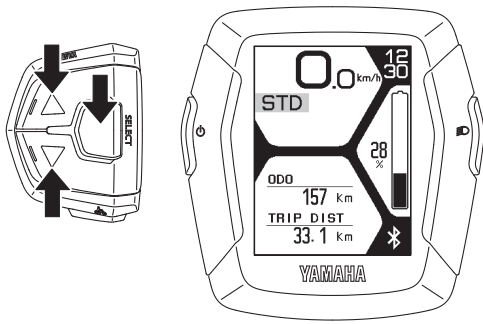

● Bluetooth (Bluetooth low energy technology)

You can set the profile to use the wireless communication function with Bluetooth low energy technology, or you can select not to use the wireless communication function.

When “Off” is selected, the wireless communication function will be inactive.

When “CSCP” is selected, the Cycling Speed and Cadence Profile will be available.

When “CPP” is selected, the Cycling Power Profile will be available.

When “YEP1.0” is selected, the e-Bike profile preset by YAMAHA MOTOR CO., LTD. will be available.

TIP

- Set the profile according to the wireless communication device that communicates via Bluetooth low energy technology.
- For the output power level of each profile, see “Specifications”.
- Even if the power is turned off, the setting will be kept. When the power is turned on the next time, the last used setting will be selected.

1. Select “Off”, “CSCP”, “CPP”, or “YEP1.0” by using the assist mode switches (up) or (down).
2. When you press the function select switch, the setting will then be kept and the display will return to the Main Menu display.

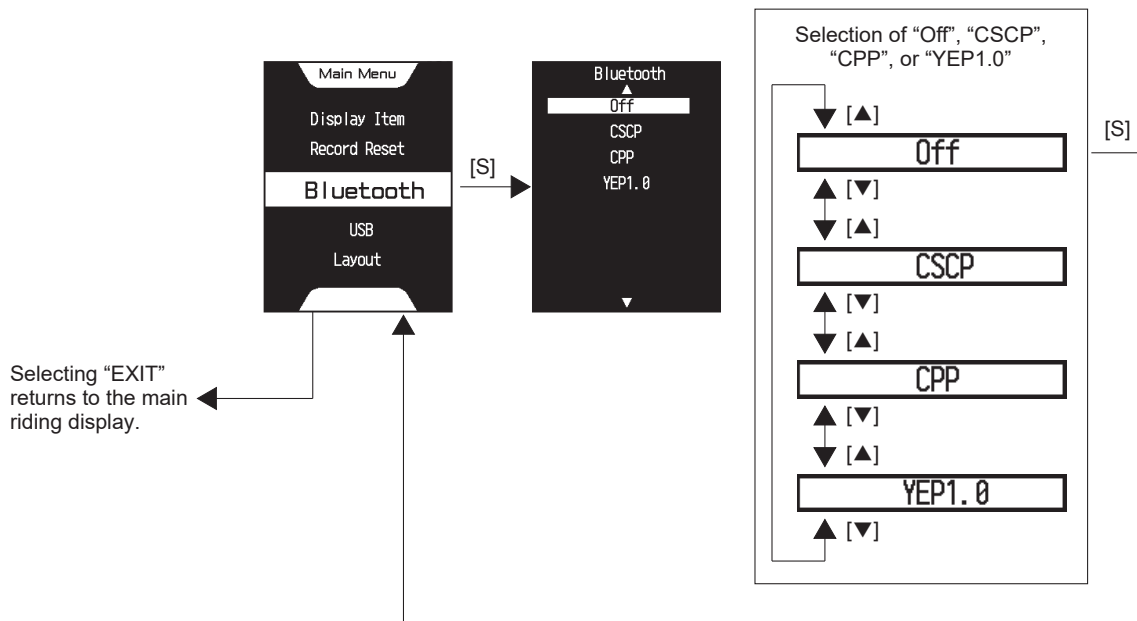

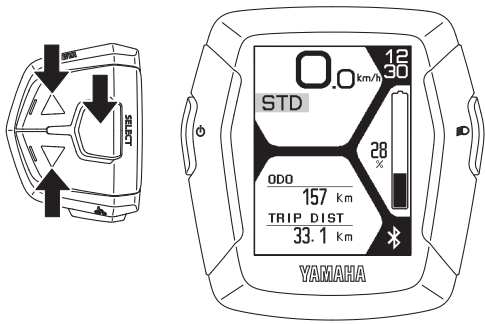

● USB

You can use the USB port as a power supply.

TIP

- Normally you should not use “COMM” because this is a service mode used for wired communication.
- When the power is turned off, the mode automatically changes to “Power Supply”.

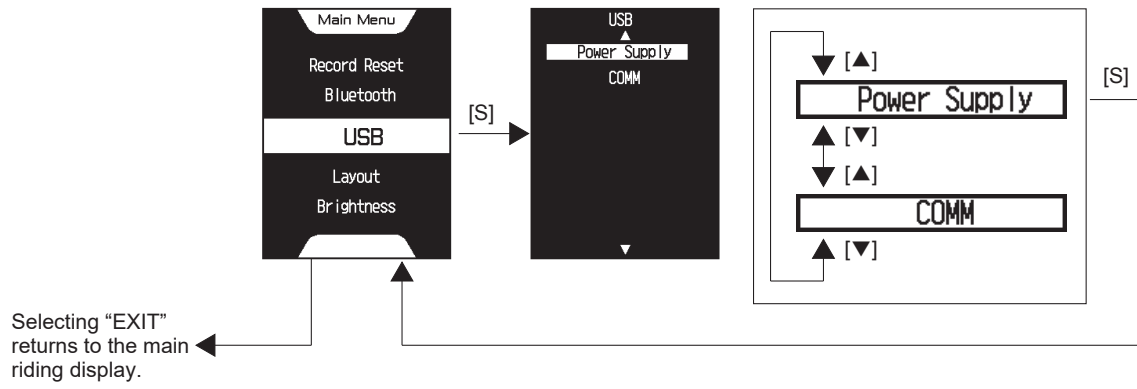

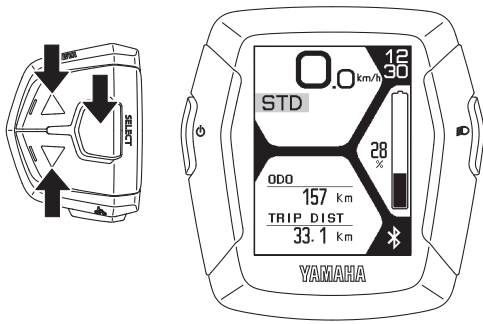

● Layout

You can select the layout for the main riding display. However, only the options from the connected smartphone application can be selected in the display.

When you select “Default”, the main riding display will be shown.

When you select “Compass”, mainly navigation information will be displayed once the unit has been paired with the smartphone application.

When you select “Fitness”, mainly fitness information will be displayed once the unit has been paired with the smartphone application.

TIP

- To display the correct information on the “Compass” and “Fitness” displays, be sure to use the Bluetooth low energy technology communication and the YEP1.0 profile in order to make the Display Unit and the smartphone application work properly together.
- When the Display Unit and smartphone application are properly paired, the Compass function and Fitness function will start on the application side, and the display will automatically change.
- When the power is turned off, the mode automatically changes to “Default”.

1. Select “Default”, “Compass”, or “Fitness” by the assist mode switches (up) or (down).
2. Press the function select switch when the desired layout is indicated in the display. This setting will then be kept and the display will return to the main riding display.

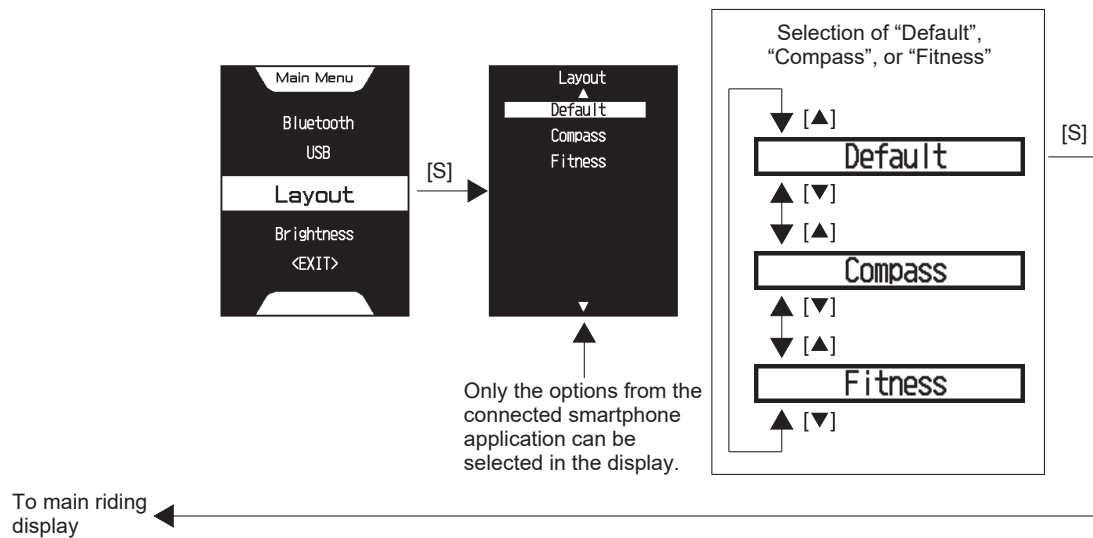

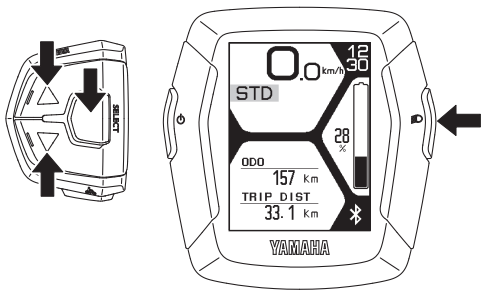

● Brightness

You can set the display backlight state when the headlight is on and off. You can select between 16 brightness and color configurations.

[Setting the display backlight brightness and color when the headlight is on]

1. Turn the headlight on by using the light switch.
2. Select the display backlight brightness and color by using the assist mode switches (up) or (down).
3. When you press the function select switch, the setting will then be kept and the display will return to the Main Menu display.

[Setting the display backlight brightness and color when the headlight is off]

1. Turn the headlight off by using the light switch.
2. Select the display backlight brightness and color by using the assist mode switches (up) or (down).
3. When you press the function select switch, the setting will then be kept and the display will return to the Main Menu display.

TIP

- While adjusting the brightness and color of the display backlight, the backlight brightness and color will become the selected one.
- Even if the power is turned off, the setting will be kept. When the power is turned on the next time, the last used setting will be selected.

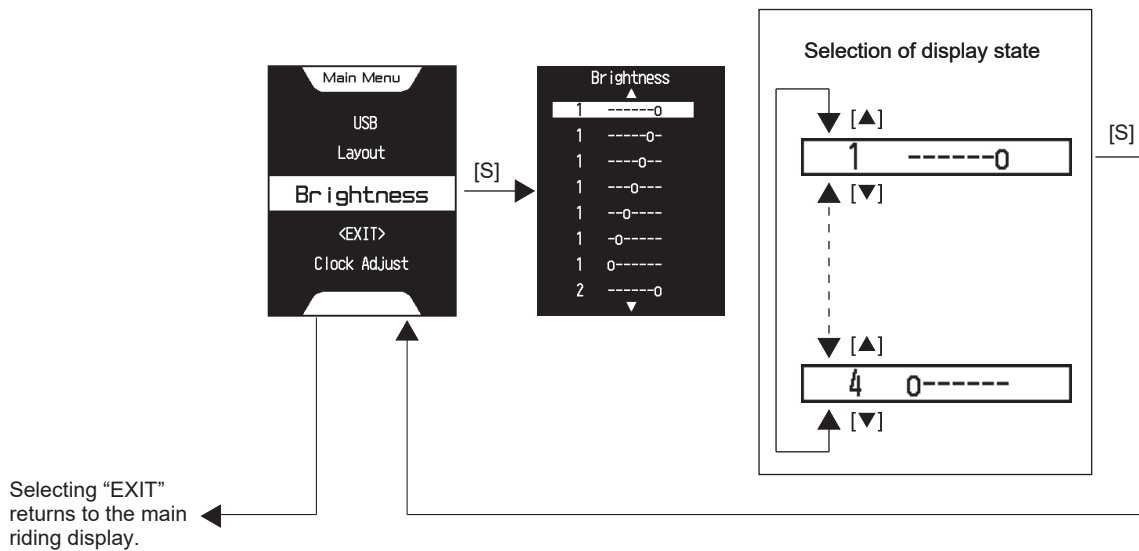

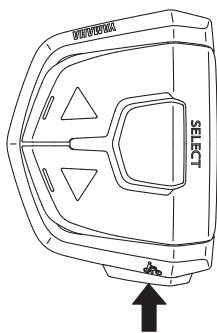

○ Walk assist

When you are on or off the bicycle and start moving it, you can use walk assist without pedaling the bicycle.

To use walk assist, press and hold the walk assist switch.

Walk assist will not work in the following situations:

- When you release the walk assist switch.
- If you press another switch at the same time.
- When you start to pedal.
- If your bicycle speed exceeds 6 km/h.
- If you select Off Mode.
- If the wheels are not turning (when braking or coming into contact with an obstacle, etc.).



○ Self-diagnosis function

The e-Bike Systems are equipped with a self-diagnosis function. If a malfunction or fault occurs in the e-Bike Systems, an error message will be displayed. For the symptoms and actions, see “Troubleshooting”.

WARNING

If the problem cannot be solved, have your bicycle inspected by a dealer as soon as possible.

○ Power supply to external devices

Power can be supplied to most external devices (e.g. various smart phones etc.) by connecting a commercial USB 2.0 OTG cable.

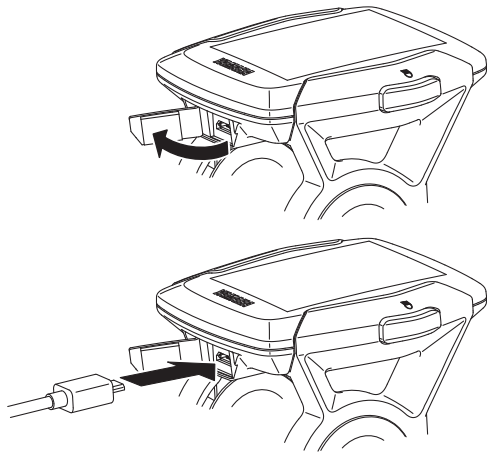

[To supply power]

1. Open the USB port cap of the display.
2. Connect the USB cable to the display and external device.
3. Turn on the power of the vehicle.

[To stop the power supply]

1. Turn off the power of the vehicle.
2. Disconnect the USB cable and put on the cap of the USB port.

NOTICE

- Do not apply unreasonable force on the USB plug or pull the USB cable.
- Check that the USB plug is facing the right way and not totally out-of-position with the USB port or slanted, and make sure it is fully inserted all the way in.
- Do not connect the USB port and the USB plug in a wet state.
- Use a USB 2.0 OTG cable that conforms to the standards.
- Do not insert foreign objects into the USB port unit. Otherwise the Display Unit and external device may malfunction.

TIP

- Power is supplied automatically when an external device is connected with the USB cable.
- No power is supplied if the remaining capacity of the Battery Pack is low.
- The power supply of the vehicle will go off and power supplied by the USB connection will also stop if the vehicle is not operated for 5 minutes.

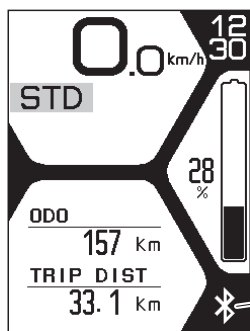

Bluetooth indicator



Ready for pairing



Paired

○ Communication with Bluetooth low energy technology

The wireless communication device corresponding to the CSCP, CPP, or YEP1.0 profiles can provide the communication via Bluetooth low energy technology.

1. Set the profiles of the Display Unit by referring to “Settings”.
Also confirm that they are in accordance with the connection settings of your wireless communication device.
2. Check that the Bluetooth indicator is displayed. 
3. Select “Yamaha #####” or “Yamaha #####*” from the user menu of your wireless communication device.
For more information, see the instruction manual of the wireless communication device.

* “#####” or “#####*” is a combination of irregular alphanumeric characters.

4. Make sure that the Bluetooth indicator displays successful pairing. 

TIP

- Keep the distance between the display and wireless communication device within 1 m. The maximum communication distance of this wireless communication device is 1 m.
If the wireless communication device is kept in a bag, etc., the actual communication distance might be shorter.
- Do not use the wireless communication device in places with magnetic fields, static electricity, or electromagnetic interference.
If the wireless communication device is used near transmitters, broadcasting stations or the following type of equipment, wireless communication may not be possible.
 - Microwave ovens
 - Digital cordless phones
 - Wireless communication devices
 - Near other wireless communication device using the 2.4 GHz band.
- Do not cover the display with objects such as aluminum sheets that block the radio waves. Otherwise, wireless communication may not be possible.
- For the output power level of each profile, see the “Specifications”.

○ Display of paired application

By using the Bluetooth low energy technology communication and YEP1.0 profile and then pairing the Display Unit with the smartphone application, navigation information (Compass) and fitness support (Fitness) will be available on the Display Unit.

⚠ WARNING

Do not concentrate on the display while bicycling since lack of attention to surrounding traffic can cause an accident.

TIP

In this manual, all information that can be shown on the Display Unit, is described. However, some information may not be correctly shown owing to the smartphone application.

● Compass (Navigation information)

Sets the destination or waypoints by using the smartphone application and shows this information on the display.

The displayed contents of the navigation information depends on the smartphone application.

You can select the information to be displayed. Push the function select switch to change the displayed information.

When the Turn-by-turn function of the smartphone application starts, only the Turn-by-turn display will be shown. Even if the function select switch is pressed, the display will not change.

When the Compass function of the smartphone application starts, you can switch the display mode among North up, Heading up, and Trip distance/time by pressing the function select switch. However, you cannot change to any other display modes.

• Turn-by-turn

The upper part shows the distance to the next turn on the traveling route to reach the destination.

The lower part shows relevant information (such as a street name, crossing name, or place name) transmitted from the application. The displayed information depends on the application.

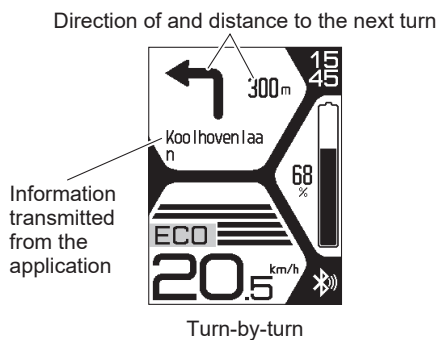

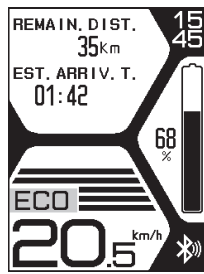

Estimated time

- **Estimated time**
The remaining distance to the destination is shown at the top.
The estimated time of arrival at the destination is shown under this.

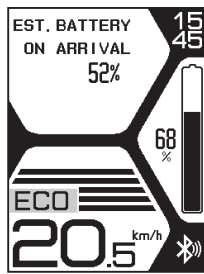

Estimated battery

- **Estimated battery**
Displays the estimated remaining battery capacity when you arrive at the destination.

Direction and straight-line distance to waypoint or destination

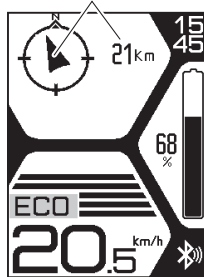

North up

- **North up**
The upper part displays the heading to the destination and straight-line distance when the compass direction of the Display Unit has been fixed to north. It displays the heading to the next waypoint and straight-line distance in case waypoints have been set.

Direction and straight-line distance to waypoint or destination

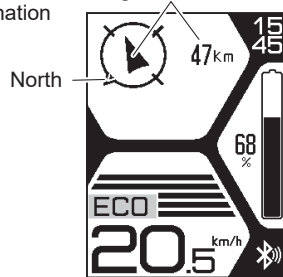

Heading up

- **Heading up**
The upper part displays the direction and straight-line distance to the destination in relation to the current traveling direction and compass direction. It displays the direction and straight-line distance to the next waypoint in relation to the compass direction in case waypoints have been set.

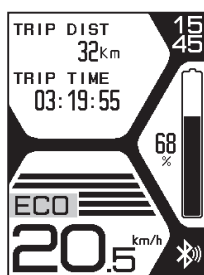

Trip distance/time

- Trip distance/time
The upper part displays the distance traveled since the smartphone application started the navigation.
The lower part displays the elapsed time since the smartphone application started the navigation.

! WARNING

Be sure to obey local traffic regulations and ride according to the actual road conditions. Otherwise, you could cause a traffic accident.

TIP

The estimated remaining battery capacity varies according to the riding mode.

● **Fitness (Fitness-support information)**

Set the target riding distance, target riding time, calorie burn target, etc. using the smartphone application and show this information on the display.

You can select the information to be displayed.

Push the function select switch, the display changes.

- Calorie/Power

The upper part displays the calorie burn target value together with the accumulated burned calories over time since the application started the Fitness function. In addition, the number of burned calories for the current ride is displayed by a bar graph.

The lower part displays the target pedal power value and current pedal power. The current pedal power is displayed by a bar graph.

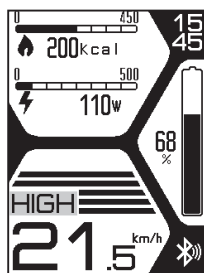

Calorie/Power

- Heart rate/Cadence

The upper part displays the target heart rate together with the current heart rate as beats per minute. In addition, the current heart rate is displayed by a bar graph.

The lower part displays the target cadence value together with the current cadence value as revolutions per minute. In addition, the current cadence value is displayed by a bar graph.

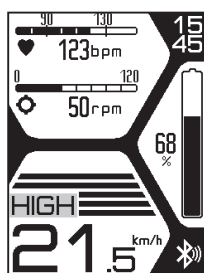

Heart rate/Cadence



Workout distance/time

- **Workout distance/time**

The upper part displays the target distance traveled value together with the accumulated distance traveled over time since the application started the Fitness function. In addition, the current distance traveled is displayed by a bar graph.

The lower part displays the target riding time value and accumulated riding time since the application started the Fitness function. In addition, the current riding time is displayed by a bar graph.

TIP

- The number of burned calories and pedal power are measured by an original method developed by YAMAHA MOTOR CO., LTD. The figures are for reference and may differ from similar figures of other products.
- In order to display the heart rate, this information must be received from a commercially available heart rate sensor supporting the smartphone application and Bluetooth low energy technology communication specifications.

The accuracy of the displayed heart rate depends on the measuring accuracy of the heart rate sensor.

Display Unit (Interface X)

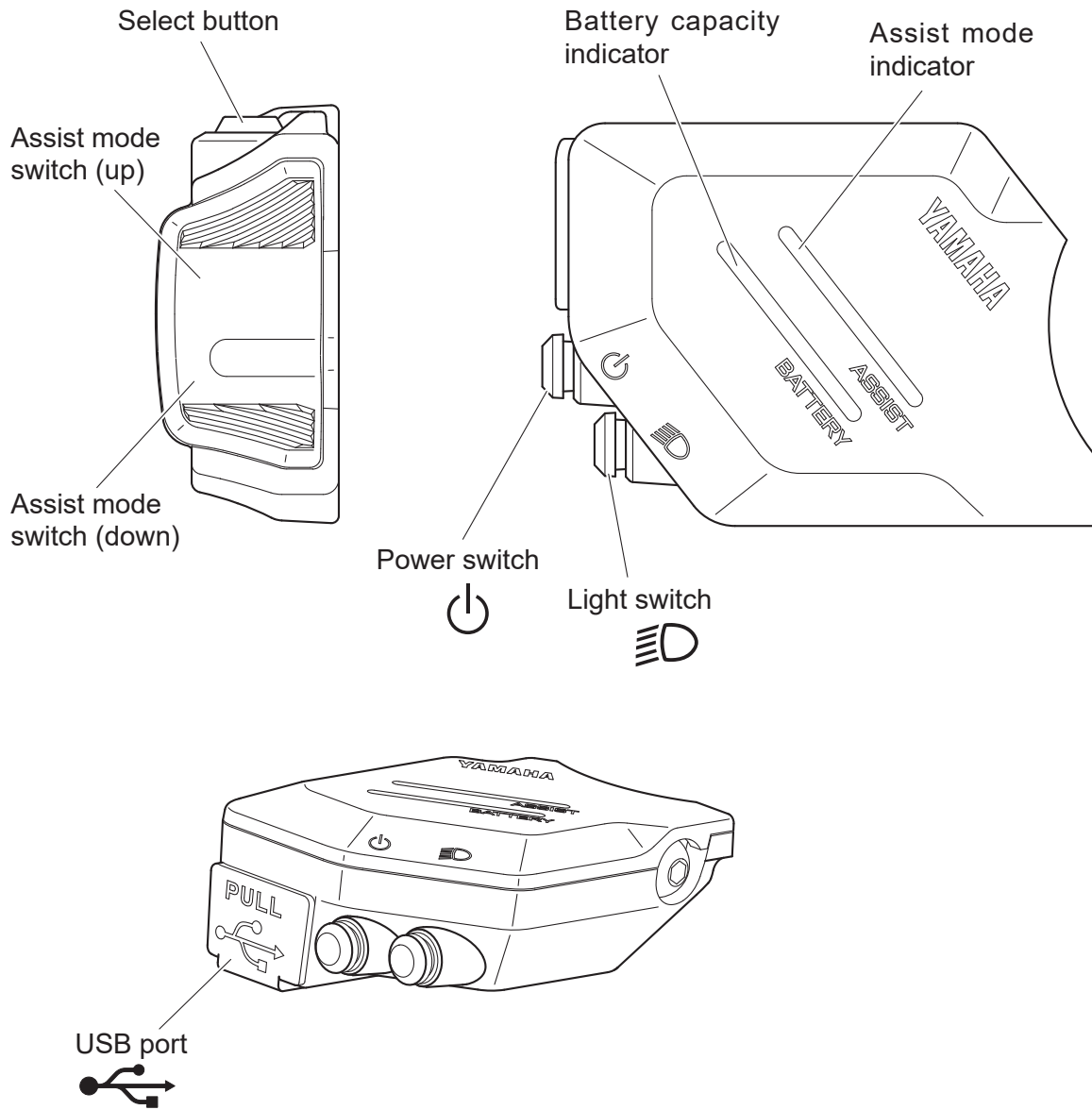

Display Unit (Interface X)

The Display Unit offers the following operations and information displays.

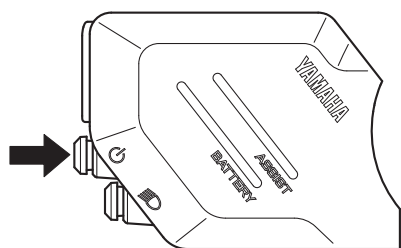
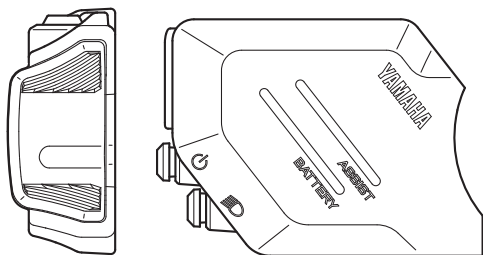

○ Power on/off

When you press the power switch, the power will be turned on and the battery capacity indicator and assist mode indicator will glow.

When you press the power switch for 1 seconds or longer, the power will be turned off.

TIP

Keep your feet off the pedals when turning on the Display Unit. Also, do not start riding immediately after turning on the Display Unit. Doing so could weaken the assist power. (Weak assist power in either of these cases is not a malfunction.) If you did either of the above by accident, remove your feet from the pedals, turn on the power again, and wait a moment (approximately two seconds) before starting to ride.

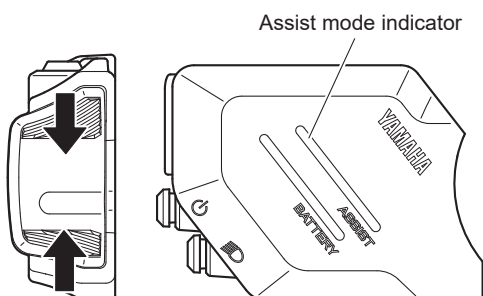

○ Displaying and switching the assist mode

You can select the assist mode by using the assist mode switches (up) or (down).

The selected assist mode is displayed by the assist mode indicator.

- When you press the assist mode switch (up), the mode changes from “OFF” to “+ECO”, or from “+ECO” to “ECO”, or “ECO” to “STD”, or “STD” to “HIGH”, or “HIGH” to “EXPW”.
- When you press the assist mode switch (down), the mode changes from “EXPW” to “HIGH”, or from “HIGH” to “STD”, or “STD” to “ECO”, or “ECO” to “+ECO”, or “+ECO” to “OFF”.

TIP

- Bicycles equipped with the PWseries CE, PWseries TE, PWseries ST, or PWseries S2 Drive Unit have no Extra Power Mode.
- Further pressing of the assist mode switch will not cycle the assist mode selections.
- When the power is turned on, the e-Bike Systems will be activated with the same assist mode as when the power was last turned off.

The Automatic Support Mode, which enables automatic change to the optimal assist mode according to the riding conditions, can also be used.

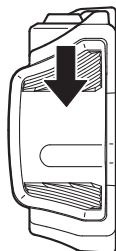

- To use the Automatic Support Mode, press the assist mode switch (up) for 1 second or longer. The rightmost lamp of the assist mode indicator will glow in Turquoise, and the mode will be changed to the Automatic Support Mode.
- To cancel the Automatic Support Mode, press the assist mode switch (up) for 1 second or longer. The rightmost lamp of the Assist mode indicator will change from Turquoise to the normal color, and the Automatic Support Mode will be canceled.

TIP

- Even if you press the assist mode switches (up) or (down) while in Automatic Support Mode, the assist mode cannot be changed.
- The Automatic Support Mode is saved when the power is turned off. When you turn on the power again, the e-Bike Systems will be activated with the Automatic Support Mode.

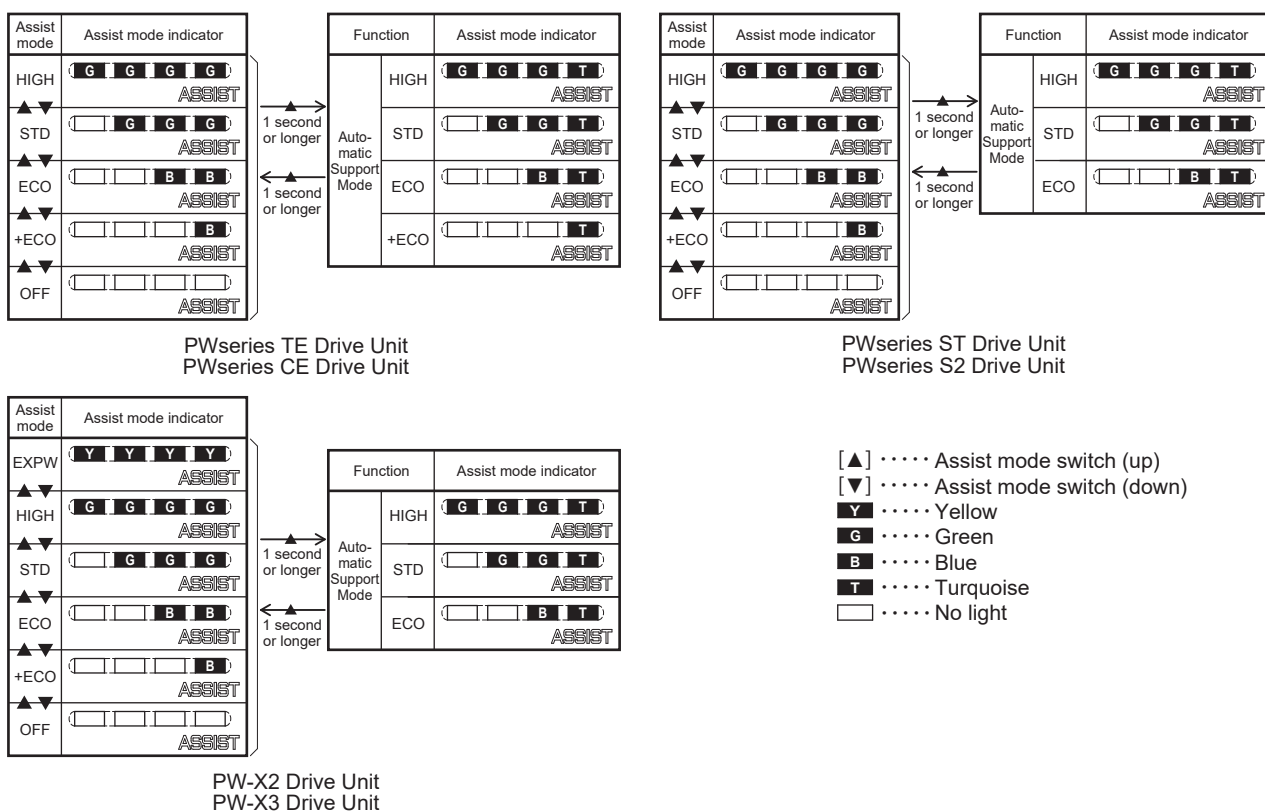

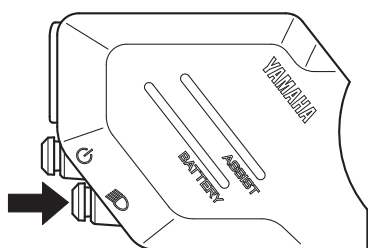
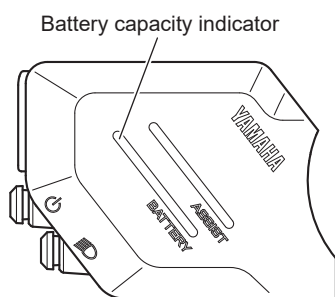

○ **Battery capacity indicator**

The battery capacity indicator displays an estimate of how much capacity is left in the Battery Pack.

○ **Headlight on/off**

For models equipped with a headlight or taillight powered by the Battery Pack, each time you press the light switch, the headlight and taillight will turn on and off.

TIP

- Indicator operates simultaneously with the light switch.
- As the light switch is turned on or off, the indicator will light accordingly. For the procedure of selecting the brightness condition, see “Settings”.
- When the power is turned on, the lights will return to the last on/off setting.

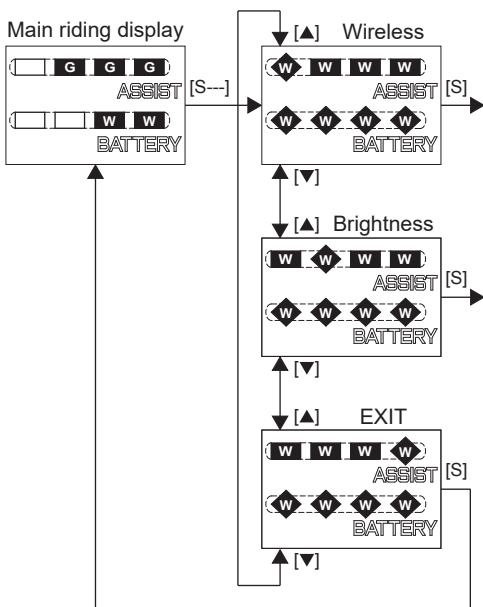
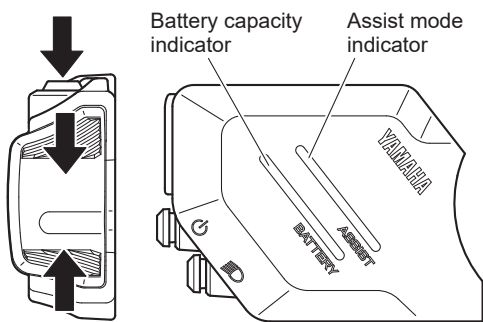

- [S---] ... Press the select button for 2 seconds or longer
- [S] ... Press the select button
- [▲] ... Assist mode switch (up)
- [▼] ... Assist mode switch (down)
- ... No light
- G ... Green
- W ... White
- ◊ ... Flashing white

○ Settings

The display enables the following.

- Wireless communication
Switches the profiles and turns off the wireless communication function.
- Brightness
Set the brightness of the indicator.

1. Press the select button for 2 seconds or longer.
When all segments of the battery capacity indicator flash, release the finger.
2. Select an item by using the assist mode switches (up) or (down).
Check the item using the assist mode indicator. For more information, see the illustration on the left.
Press the select button at the displayed item that you want to select, and the selected item will then be displayed.
Selecting “EXIT” returns to the main riding display.

⚠ WARNING

For all setting procedures, be sure to stop the bicycle and perform the required settings in a safe location. Otherwise, lack of attention to surrounding traffic or other hazards could cause an accident.

TIP

- The settings cannot be adjusted while riding.
- If you do the following during setting, the item that you are setting will be canceled and the display will return to the main riding display.
 - Turning the crank (pedal) in the traveling direction
 - Turning the rear wheel at 2 km/h and more
 - Pushing the walk assist switch

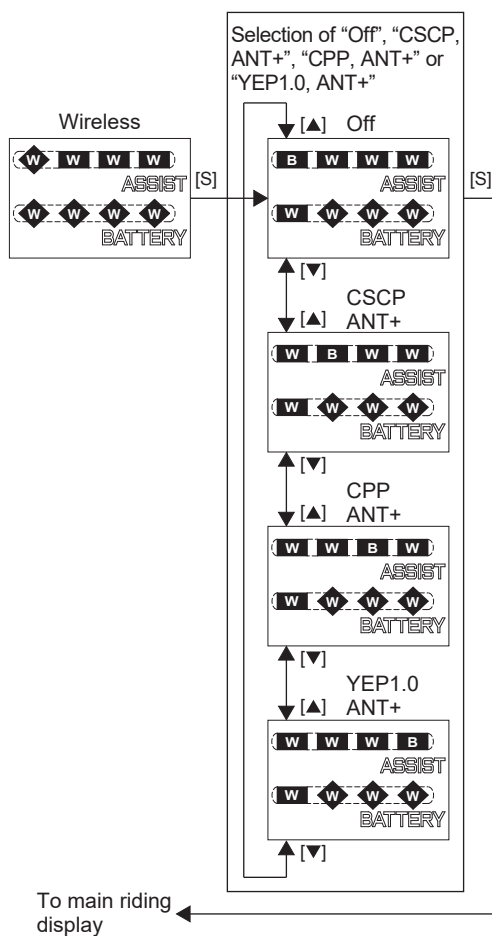
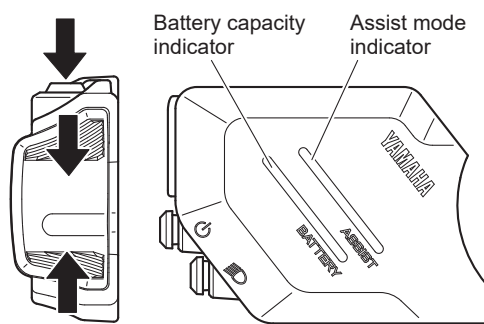

- [S] Press the select button
- [▲] Assist mode switch (up)
- [▼] Assist mode switch (down)
- W White
- W Flashing white
- B Blue

● Wireless communication

You can set the profile to use the wireless communication function at the same time with Bluetooth low energy technology and ANT+, or you can select not to use the wireless communication function.

When "Off" is selected, the wireless communication function will be inactive.

When "CSCP" is selected, the Cycling Speed and Cadence Profile will be available together with "Ant+*".

When "CPP" is selected, the Cycling Power Profile will be available together with "Ant+*".

When "YEP1.0" is selected, the e-Bike profile preset by YAMAHA MOTOR CO., LTD. will be available together with "Ant+*".

* When ANT+ is active, Speed and cadence, Power, and LEV are possible to use in parallel.



TIP

- Set the profile according to the wireless communication device that communicates via Bluetooth low energy technology.
- For the output power level of each profile, see "Specifications".
- Even if the power is turned off, the setting will be kept. When the power is turned on the next time, the last used setting will be selected.

1. Select "Off", "CSCP, ANT+", "CPP, ANT+", or "YEP1.0, ANT+" by using the assist mode switches (up) or (down).
2. When you press the select button at the desired item display, the setting will be kept and the main riding display will be shown.

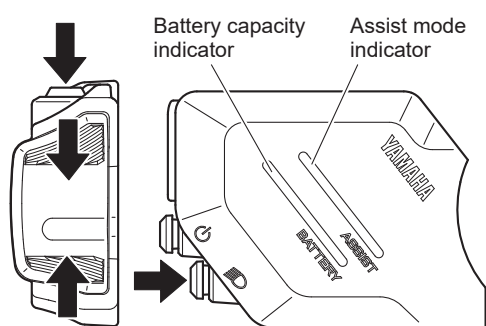

● Brightness

You can set the indicator brightness when the headlight is on and off.

[Setting the indicator brightness when the headlight is on]

1. Turn the headlight on by using the light switch.
2. Select the indicator brightness by using the assist mode switches (up) or (down).
3. When you press the select button, the setting will then be kept and the display will return to the main riding display.

[Setting the indicator brightness when the headlight is off]

1. Turn the headlight off by using the light switch.
2. Select the indicator brightness by using the assist mode switches (up) or (down).
3. When you press the select button, the setting will then be kept and the display will return to the main riding display.

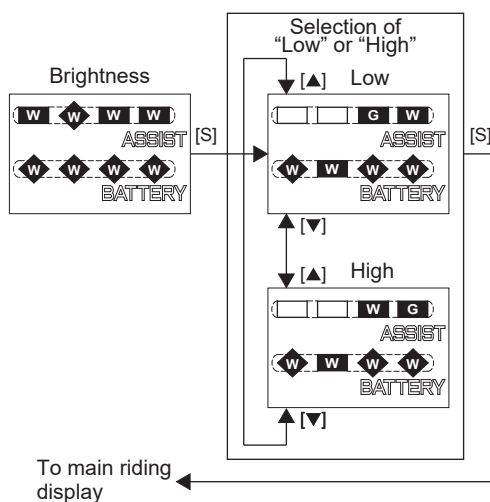

- [S] Press the select button
- [▲] Assist mode switch (up)
- [▼] Assist mode switch (down)
- W White
- W Flashing white
- No light
- G Green

TIP

- While adjusting the brightness of the indicator, the indicator brightness will become the selected one.
- Even if the power is turned off, the setting will be kept. When the power is turned on the next time, the last used setting will be selected.

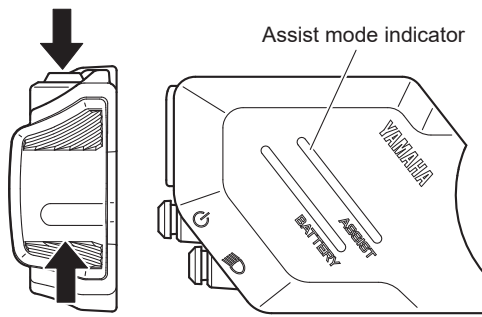

***** Depends on the assist mode at that time.

Pu Purple

○ Walk assist

When you are on or off the bicycle and start moving it, you can use walk assist without pedaling the bicycle.

Walk assist will not work in the following situations:

- When you release the assist mode switch (down).
- If you press another switch at the same time.
- When you start to pedal.
- If your bicycle speed exceeds 6 km/h.
- If you select Off Mode.
- If the wheels are not turning (when braking or coming into contact with an obstacle, etc.).

1. When you press the select button, the rightmost lamp of the assist mode indicator will light up in purple for 2 seconds.

When left for 2 seconds without doing anything or if you press any other switch than the select button or assist mode switch (down), it will return to the original state.

2. By holding the assist mode switch (down) pressed while the rightmost lamp of the assist mode indicator lights up in purple, the walk assist function is usable.

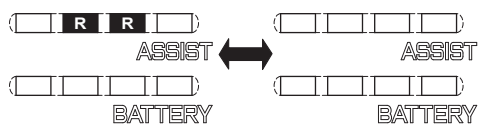
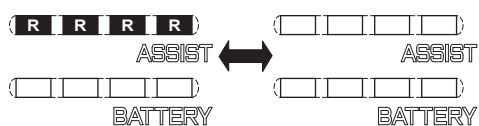

R Red
 □ No light

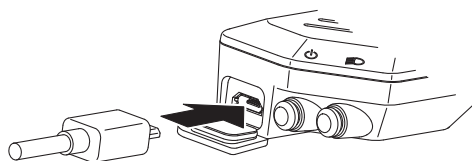
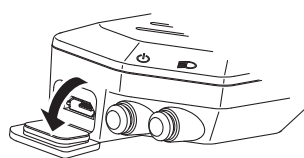

○ Self-diagnosis function

The e-Bike Systems are equipped with a self-diagnosis function. If a malfunction or fault occurs in the e-Bike Systems, the assist mode indicator will flash in red. See “Troubleshooting” regarding symptoms and remedies for abnormal displays and abnormal flashing.

! WARNING

If the problem cannot be solved, have your bicycle inspected by a dealer as soon as possible.

○ Power supply to external devices

Power can be supplied to most external devices (e.g. various smart phones etc.) by connecting a commercial USB 2.0 OTG cable.

[To supply power]

1. Open the USB port cap of the display.
2. Connect the USB cable to the display and external device.
3. Turn on the power of the vehicle.

[To stop the power supply]

1. Turn off the power of the vehicle.
2. Disconnect the USB cable and put on the cap of the USB port.

NOTICE

- Do not apply unreasonable force on the USB plug or pull the USB cable.
- Check that the USB plug is facing the right way and not totally out-of-position with the USB port or slanted, and make sure it is fully inserted all the way in.
- Do not connect the USB port and the USB plug in a wet state.
- Use a USB 2.0 OTG cable that conforms to the standards.
- Do not insert foreign objects into the USB port unit. Otherwise the Display Unit and external device may malfunction.

TIP

- Power is supplied automatically when an external device is connected with the USB cable.
 - No power is supplied if the remaining capacity of the Battery Pack is low.
 - The power supply of the vehicle will go off and power supplied by the USB connection will also stop if the vehicle is not operated for 5 minutes.
 - It is normal to become somewhat warm during power supply.
-

○ Communication with Bluetooth low energy technology

The wireless communication device corresponding to the CSCP, CPP, or YEP1.0 profiles can provide the communication via Bluetooth low energy technology.

1. Set the profiles of the Display Unit by referring to “Settings”.
Also confirm that they are in accordance with the connection settings of your wireless communication device.
2. Select “Yamaha X2Y #####*” from the user menu of your wireless communication device.
For more information, see the instruction manual of the wireless communication device.

* “#####” is a combination of irregular alphanumeric characters.

TIP

- Keep the distance between the display and wireless communication device within 1 m. The maximum communication distance of this wireless communication device is 1 m.
If the wireless communication device is kept in a bag, etc., the actual communication distance might be shorter.
 - Do not use the wireless communication device in places with magnetic fields, static electricity, or electromagnetic interference.
If the wireless communication device is used near transmitters, broadcasting stations or the following type of equipment, wireless communication may not be possible.
 - Microwave ovens
 - Digital cordless phones
 - Wireless communication devices
 - Near other wireless communication device using the 2.4 GHz band.
 - Do not cover the communication unit with objects such as aluminum sheets that block the radio waves. Otherwise, wireless communication may not be possible.
 - For the output power level of each profile, see the “Specifications”.
-

○ **Communication with ANT+**

The wireless communication device corresponding to the Speed and cadence, Power, and LEV profiles can provide the communication via ANT+.

1. Set the ANT+ of the Display Unit by referring to “Settings”.
2. Execute pairing with your ANT+ display without other ANT+ device nearby.

TIP

- Keep the distance between the display and wireless communication device within 1 m. The maximum communication distance of this wireless communication device is 1 m.

If the wireless communication device is kept in a bag, etc., the actual communication distance might be shorter.

- Do not use the wireless communication device in places with magnetic fields, static electricity, or electromagnetic interference.

If the wireless communication device is used near transmitters, broadcasting stations or the following type of equipment, wireless communication may not be possible.

- Microwave ovens
 - Digital cordless phones
 - Wireless communication devices
 - Near other wireless communication device using the 2.4 GHz band.
 - Do not cover the communication unit with objects such as aluminum sheets that block the radio waves. Otherwise, wireless communication may not be possible.
-

H. Battery Pack and charging procedure

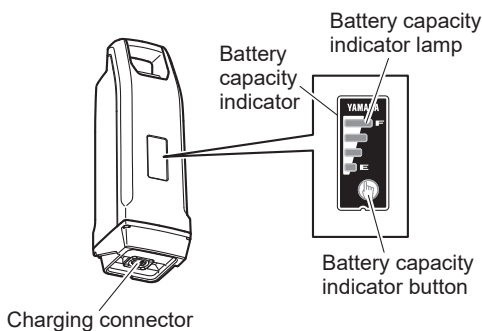
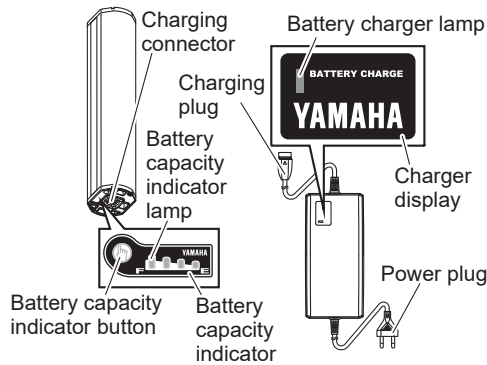
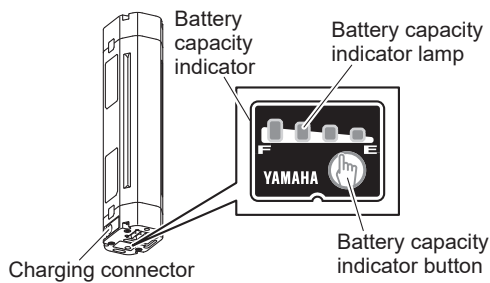
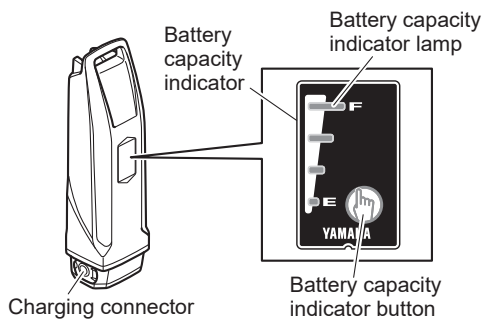
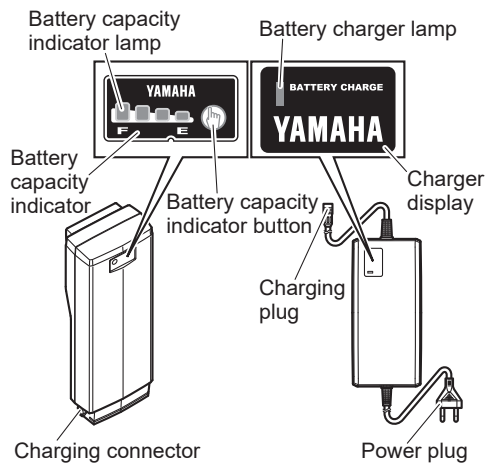

The Battery Pack equipped for the Yamaha e-Bike Systems is a lithium-ion battery. The lithium-ion battery is lightweight and offers superior capacity. However, it does have the following characteristics.

- Its performance decreases in extremely hot or cold environments.
- It naturally loses its charge.

The Battery Pack for the Yamaha e-Bike Systems also has an embedded computer which notifies you of estimated residual battery capacity and suspected faults via the battery capacity indicator lamp.

By pressing the battery capacity indicator button, you can display the residual battery capacity for approximately 5 seconds.

See “Checking the residual battery capacity” for the estimate of the residual battery capacity. See “Troubleshooting” for information on fault flashing.

WARNING

Do not use any other charger or charging method to recharge the Battery Packs. Using any other charger could result in fire, explosion, or damage the Battery Packs.

WARNING

IMPORTANT SAFETY INSTRUCTIONS — SAVE THESE INSTRUCTIONS TO REDUCE THE RISK OF FIRE OR ELECTRIC SHOCK, CAREFULLY FOLLOW THESE INSTRUCTIONS

This manual contains important safety and operating instructions for Battery Charger type PASC9 and PASC10. Those types can be found in the labels on the products.

Before using Battery Charger, read all instructions and cautionary markings on Battery Charger, Battery Pack and product using Battery Pack.

Only use the Battery Charger type PASC10 to charge PASB2, PASB4, and PASB5 type Battery Packs for Yamaha e-Bike Systems, while only using the Battery Charger type PASC9 to charge PASB6 type Battery Pack for Yamaha e-Bike Systems. Other types of batteries may burst causing injury to persons and damage.

NOTICE

Do not apply grease on the terminal of the Battery Pack.

Appropriate charging environments

For safe and efficient charging, charge the Battery Pack in a location that is:

- Flat and stable
- Free of rain or moisture
- Out of direct sunlight
- Well-ventilated and dry
- Not accessible to children or pets
- Temperature between 15–25 °C

Inappropriate charging environments and solutions

The hot and cold environments described below can cause charging to enter standby or suspension without fully charging the Battery Pack.

- Summertime charging standby/suspension

If charging in a location receiving direct summer sunlight or immediately after riding, the Battery Pack might enter charging standby (all four battery capacity indicator lamps flash slowly). See “Reading the charging status for Battery Pack”. This is to automatically stop charging in order to protect the Battery Pack from exceeding the specified temperature while charging. You can avoid charging suspension by starting to charge with the Battery Pack cold or at a room temperature of 15–25 °C. If charging suspension occurs, move the Battery Pack to a cool location to reduce the charging standby time.

- Wintertime charging standby/suspension

Charging standby will occur if the temperature is less than 0 °C. If charging is started and the temperature drops below this level due to late-night cooling or other factors, charging is suspended and standby mode is entered to protect the Battery Pack. In such cases, restart charging at an indoor location with a temperature of 15–25 °C.

- Noise on televisions/radios/computers

Charging next to televisions, radios, or similar appliances might cause static, flickering images, and other interference. If this occurs, recharge in a location further away from the television or radio (such as in another room).

WARNING

If a charging fault occurs during charging, remove the power plug of the Battery Charger from the socket and wait for the Battery Pack/Battery Charger to cool.

Charging the Battery Pack mounted on the bicycle (Rear Carrier Battery)

1. Connect the power plug of the Battery Charger to a household power outlet.
2. Remove the lid of the battery holder cover and the cap of charging inlet from the charging connector on the Battery Pack, and connect it to the charging plug on the Battery Charger.

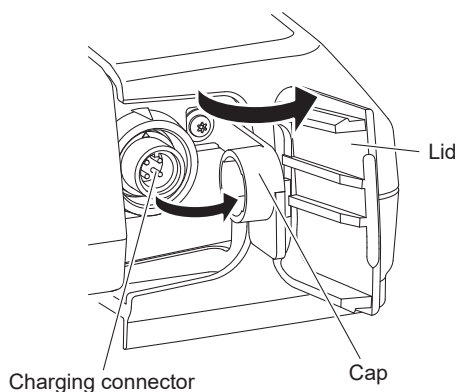
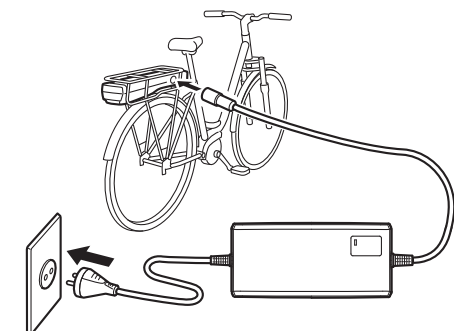

Charging the Battery Pack mounted on the bicycle (Down Tube Battery)

1. Connect the power plug of the Battery Charger to a household power outlet.
2. Remove the cap of charging inlet from the charging connector on the Battery Pack, and connect it to the charging plug on the Battery Charger.

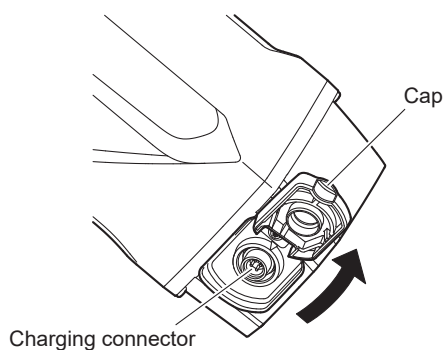
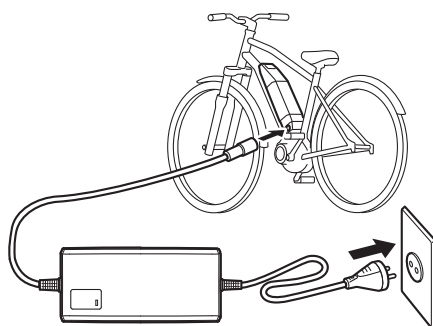

Charging the Battery Pack mounted on the bicycle (Multi Location Battery, External Crossover Battery)

1. Connect the power plug of the Battery Charger to a household power outlet.
2. Remove the cap of charging inlet from the charging connector on the bicycle, and connect it to the charging plug on the Battery Charger. How to open the cap varies between bicycles.

NOTICE

- Do not connect the charging plug of the Battery Charger with the charging connector of the Battery Pack in a wet state. Otherwise, the Battery Charger and Battery Pack may malfunction.
- Be sure to connect the charging plug only after the charging connector on the Battery Pack is completely dry. Otherwise, the Battery Charger and Battery Pack may malfunction.
- Do not apply excessive force to the charging plug or pull on the cord with the charging plug connected to the Battery Pack. Otherwise, the charging plug or connector may be damaged.
- Do not pedal while the charging plug is connected.

3. See “Reading the charging status for Battery Pack”, and check that the Battery Charger is charging the Battery Pack.
4. The battery capacity indicator lamps will light up one by one until all four are on. Then, when charging is complete, all of the lamps will go off.
5. Confirm that charging is complete, and then disconnect the charging plug from the Battery Pack. How to disconnect the charging plug of Battery Charger type PASC10 (see the left figure)
 - ① Grasp the lock-release ring.
 - ② Pull it out straight.
6. Place the cap of charging inlet on the Battery Pack’s charging connector.

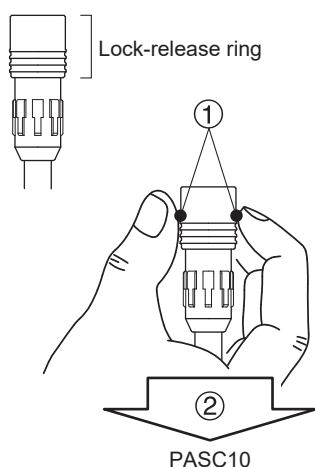

WARNING

Never handle the power plug, charging plug or touch the Battery Charger contacts with wet hands. This could result in electric shock.

TIP

- Charging will start automatically.
- If the Display Unit is turned on while the Battery Pack is charging, all normal displays will be shown, including the battery capacity indicator, but the assist system will not function.
- When the Battery Pack is connected to the Battery Charger, the battery capacity indicator lamp will flash at approximately 0.2 second intervals to indicate that the Battery Pack is being prepared to be charged. Leave it alone and charging will start normally.
- If you charge the Battery Pack with the Battery Pack installed in the bicycle, the headlight might go off.

Charging the Battery Pack removed from the bicycle

1. Turn the Display Unit off.
2. Insert the key into the battery lock, and turn it to release the battery lock.
3. Remove the Battery Pack.

! WARNING

Use both hands when removing the Battery Pack. Do not drop the Battery Pack or subject it to impact. Doing so could cause the Battery Pack to become hot or catch fire, resulting in serious injury or property damage.

TIP

How to remove Multi Location Batteries varies between bicycles. For more information, see the instruction manual supplied with the bicycle.

4. Connect the power plug of the Battery Charger to a household power outlet.
5. Remove the cap from the charging connector on the Battery Pack, and connect it to the charging plug on the Battery Charger.

The Multi Location Battery 400/500 and External Crossover Battery 400/500 are not equipped with a cap.

NOTICE

- Do not connect the charging plug of the Battery Charger with the charging connector of the Battery Pack in a wet state. Otherwise, the Battery Charger and Battery Pack may malfunction.
- Be sure to connect the charging plug only after the charging connector on the Battery Pack is completely dry. Otherwise, the Battery Charger and Battery Pack may malfunction.
- Do not apply excessive force to the charging plug or pull on the cord with the charging plug connected to the Battery Pack. Otherwise, the charging plug or connector may be damaged.

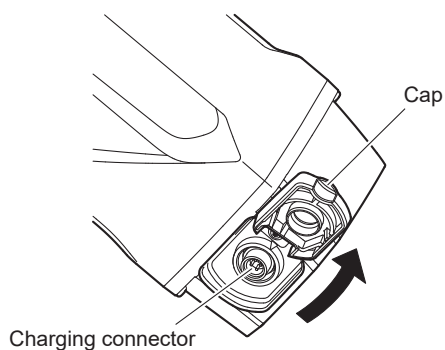
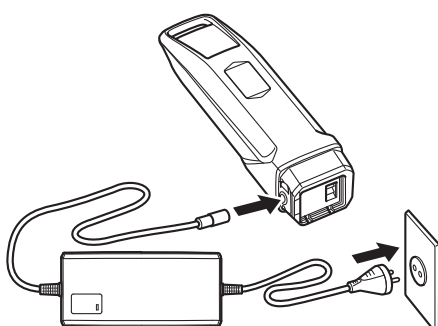
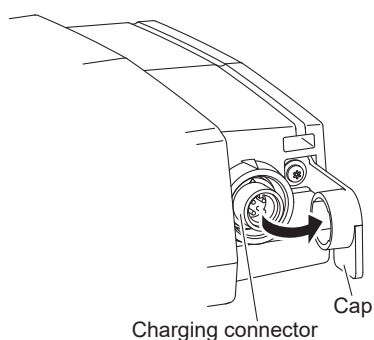
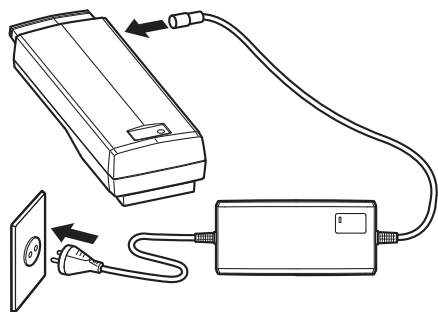

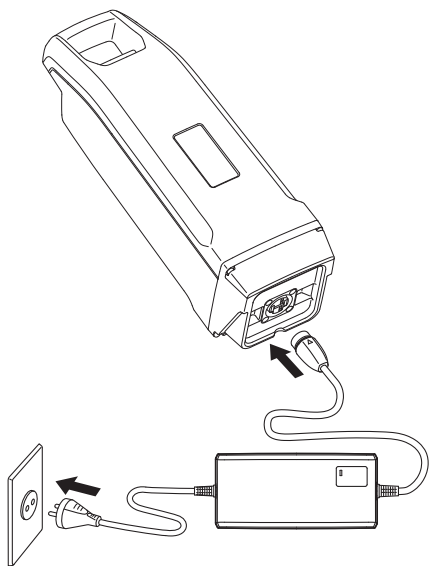
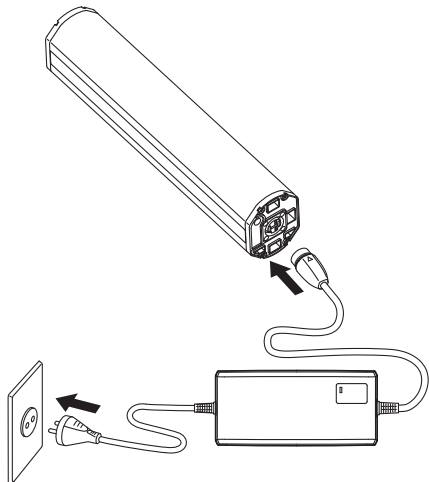
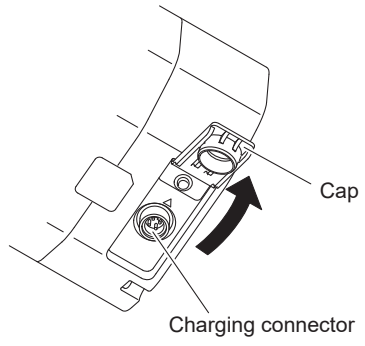
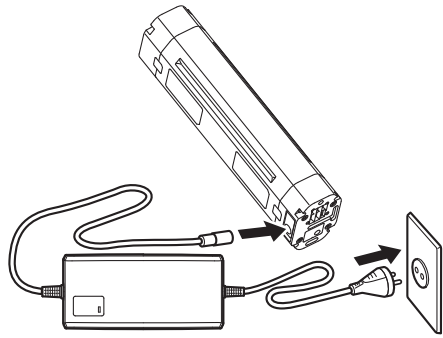

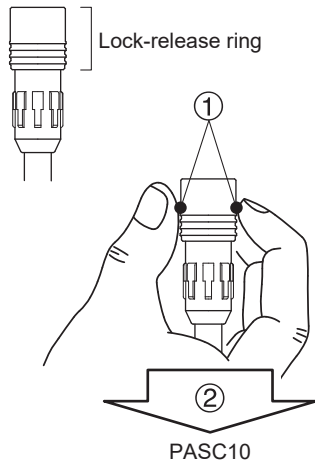

6. See “Reading the charging status for Battery Pack”, and check that the Battery Charger is charging the Battery Pack.
7. The battery capacity indicator lamps will light up one by one until all four are on. Then, when charging is complete, all of the lamps will go off.
8. Confirm that charging is complete, and then disconnect the charging plug from the Battery Pack.
How to disconnect the charging plug of Battery Charger type PASC10 (see the left figure)
 - ① Grasp the lock-release ring.
 - ② Pull it out straight.
9. Place the cap on the Battery Pack’s charging connector.
The Multi Location Battery 400/500 and External Crossover Battery 400/500 are not equipped with a cap.
10. Mount the Battery Pack on the bicycle.

⚠ WARNING

- **Do not touch Battery Charger contacts with metallic objects. Do not allow foreign material to cause short circuit of the contacts. This could result in electric shock, fire, or damage the Battery Charger.**
- **Periodically remove dust from the power plug. Dampness or other issues could reduce the effectiveness of the insulation, resulting in fire.**
- **Never disassemble or modify the Battery Charger. This could result in fire or electric shock.**
- **Do not use with a power strip or extension cord. Using a power strip or similar methods may exceed rated current and can result in fire.**
- **Do not use with the cable tied or rolled up, and do not store with the cable wrapped around the Battery Charger main body. Cable damage can result in fire or electric shock.**
- **Firmly insert the power plug and the charging plug into the socket. Failure to insert the power plug and the charging plug completely can result in fire caused by electric shock or overheating.**
- **Do not use the Battery Charger near flammable material or gas. This could result in fire or explosion.**
- **Never cover the Battery Charger or place other objects on top of it while charging. This could result in internal overheating leading to fire.**
- **Before equipping the bicycle with a Multi Location Battery 400/500, make sure that there is no foreign matter or water in the connector on the bicycle. Otherwise, it could lead to heat generation, smoke and/or a fire owing to short-circuiting of the terminals.**

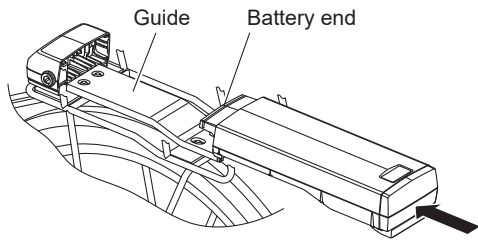

TIP

Battery Pack mounting method (Rear Carrier Battery)

The Battery Pack is installed from behind the rear carrier.

- Put the battery end on top of the guide.
- Slide the Battery Pack in the direction of the arrow until hearing a click.

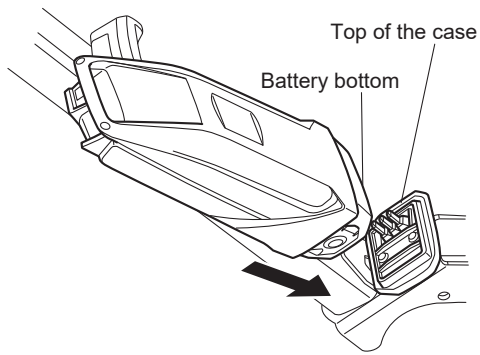

TIP

Battery Pack mounting method (Down Tube Battery)

Insert the Battery Pack in the direction of the arrow so that the battery bottom is aligned to the top of the case.

- Insert the upper part of the Battery Pack in the direction of the arrow so that the battery handle is aligned to the top of the battery lock.
- Press the upper part of the Battery Pack toward the frame until it clicks into place to secure it.

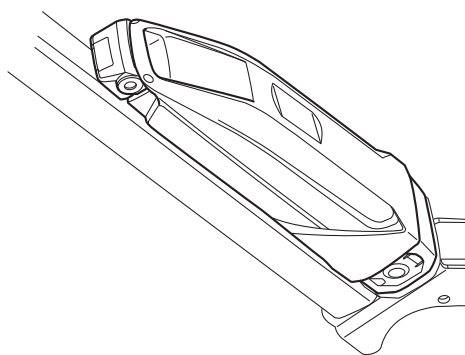
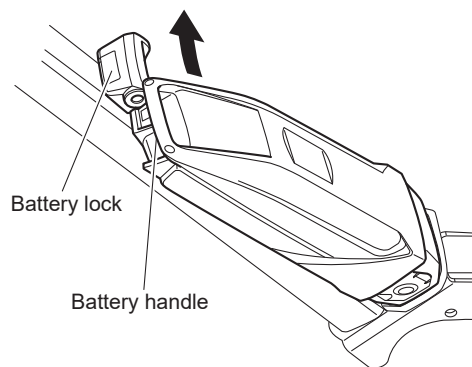

TIP

Battery Pack mounting method (Multi Location Battery)

How to install Multi Location Batteries varies between bicycles. For more information, see the instruction manual supplied with the bicycle.

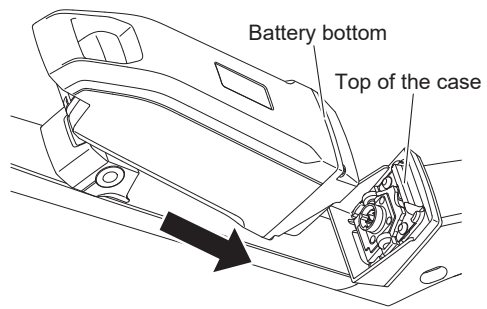

TIP

Battery Pack mounting method (External Crossover Battery)

- Insert the Battery Pack in the direction of the arrow so that the battery bottom is aligned to the top of the case.
- Press the upper part of the Battery Pack toward the frame until it clicks into place to secure it.

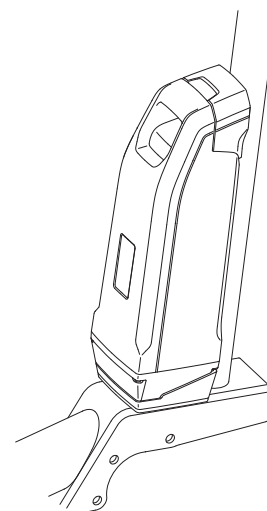
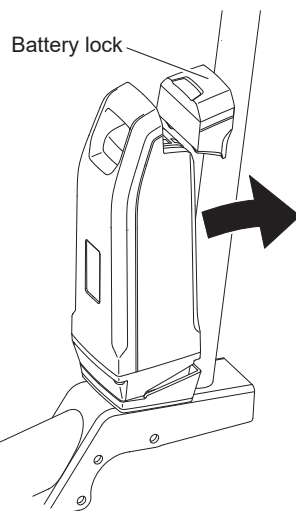
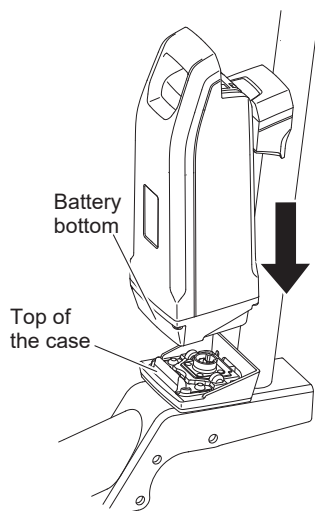
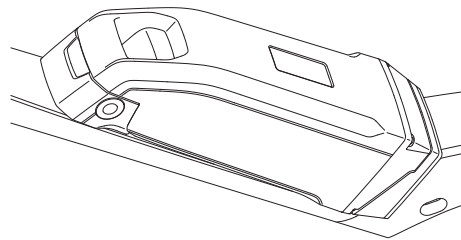
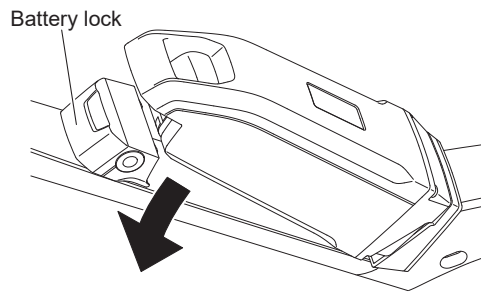

11. Make sure that it is securely attached by pulling the Battery Pack after installation.





⚠ WARNING







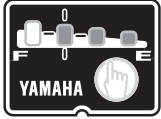
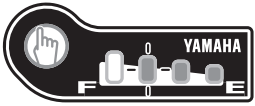

- Do not short the contacts of the Battery Pack. Doing so could cause the Battery Pack to become hot or catch fire, resulting in serious injury or property damage.
- Do not disassemble or modify the Battery Pack. Doing so could cause the Battery Pack to become hot or catch fire, resulting in serious injury or property damage.
- Do not dispose of the Battery Pack in a fire or expose it to a heat source. Doing so could cause an explosion, resulting in serious injury or property damage.
- Do not drop the Battery Pack or subject it to impact. Doing so could cause the Battery Pack to become hot or catch fire, resulting in serious injury or property damage.

NOTICE

Make sure there is no foreign matter on the Battery Pack contacts before inserting the Battery Pack.

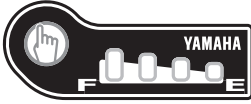
Reading the charging status for Battery Pack

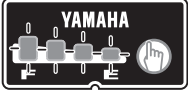
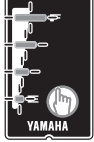
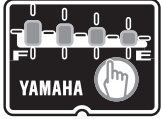
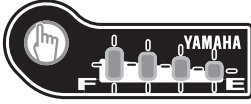



Battery charger lamp	Battery capacity indicator lamps	Current status	Details
 <p>On</p>	<p>Lit battery capacity indicator lamps indicate the amount of charging completed. A flashing battery capacity indicator lamp indicates current progress.</p> <p>(Rear Carrier Battery) (Down Tube Battery)</p>   <p>(Multi Location Battery)</p>   <p>(External Crossover Battery)</p>  <p>(Example: Battery is approximately 50–75 % charged.)</p>	Charging	During charging, the battery capacity indicator lamps light up one by one.

Battery charger lamp	Battery capacity indicator lamps	Current status	Details
 Off	<p>(Rear Carrier Battery) (Down Tube Battery)</p>   <p>(Multi Location Battery)</p>   <p>(External Crossover Battery)</p>  Off	Charging completed	When charging is complete, the battery charger lamp on the Battery Charger and the battery capacity indicator lamp on the Battery Pack go off.
Off	<p>Four lamps flash simultaneously.</p> <p>(Rear Carrier Battery) (Down Tube Battery)</p>   <p>(Multi Location Battery)</p>   <p>(External Crossover Battery)</p> 	Battery Pack is in standby mode. * The Battery Pack internal temperature is too high or too low.	Charging will automatically restart when a temperature is reached that allows charging. (See “Appropriate charging environments”.) When possible, always perform charging at the optimal temperature of 15–25 °C.

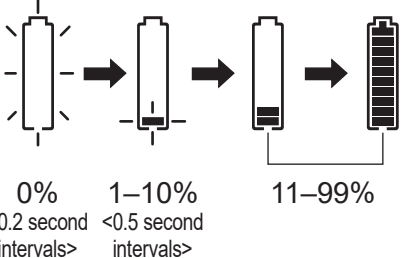
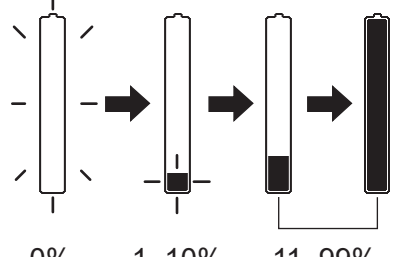
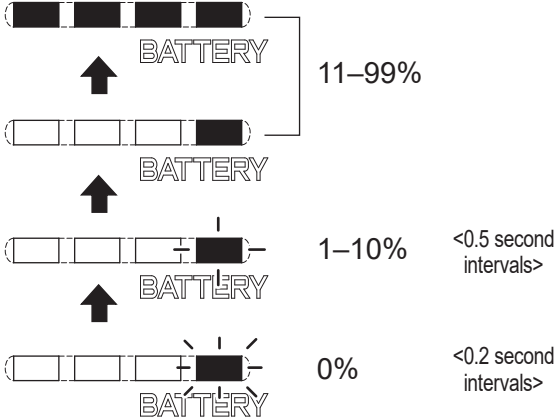
Reading the charging status for Display Unit (Applies only to models equipped with the Multi Location Battery.)

To check the charge status, turn on the power of the Display Unit.

Battery charger lamp	Display Unit	Current status	Details
 <p>On</p>	<p>(Display A)</p>  <p>0% 1-10% 11-99%</p> <p><0.2 second intervals> <0.5 second intervals></p> <p>(Display C)</p>  <p>0% 1-10% 11-99%</p> <p><0.2 second intervals> <0.5 second intervals></p> <p>(Interface X)</p>  <p>11-99% <0.5 second intervals></p> <p>1-10% <0.5 second intervals></p> <p>0% <0.2 second intervals></p>	<p>Charging</p>	<p>The battery capacity indicator slowly increases.</p>

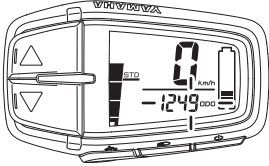
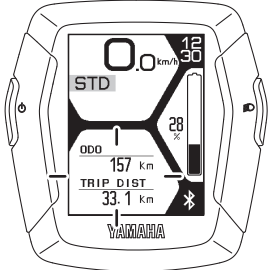
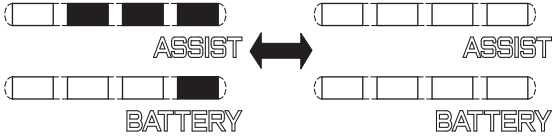
Battery charger lamp	Display Unit	Current status	Details
	<p>(Display A) All segments of the battery capacity indicator light up.</p>  <p>(Display C) All segments of the battery capacity indicator light up.</p>  <p>(Interface X) All lamps of the battery capacity indicator light up.</p> 	Charging completed	When charging is complete, all segments of the battery capacity indicator of the Display Unit will go off and the battery charger lamp of the Battery Charger will go out.
 Off	<p>(Display A) All function display items are flashing.</p>  <p>(Display C) All function display items are flashing.</p>  <p>(Interface X) Assist mode indicator and battery capacity indicator will flash. Flashing lamp depends on the situation at that time.</p> 	<p>Battery Pack is in standby mode. * The Battery Pack internal temperature is too high or too low.</p>	<p>Charging will automatically restart when a temperature is reached that allows charging. (See “Appropriate charging environments”.)</p> <p>When possible, always perform charging at the optimal temperature of 15–25 °C.</p>

TIP

For example, even if normal charging is started, if the Battery Pack temperature or the surrounding temperature is too high or too low, the charging may be extended or charging may be stopped without the Battery Pack being charged sufficiently in order to protect the Battery Pack.

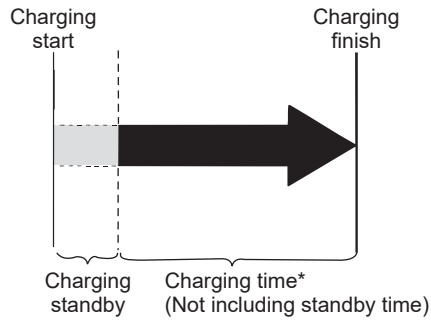

Charging time guidelines

Although charging time varies depending on residual battery capacity and external temperature, if the Battery Pack has been exhausted, this time is typically as indicated in the table below.

Battery Pack	Charging time
Rear Carrier Battery 400	3.5 hours
Down Tube Battery 400	
Multi Location Battery 400	
External Crossover Battery 400	
Rear Carrier Battery 500	4 hours
Down Tube Battery 500	
Multi Location Battery 500	
External Crossover Battery 500	5 hours
Multi Location Battery 600	

If the Battery Pack enters standby mode while charging, charging time will increase by an equal amount.

* If charging after a long period of disuse, the charging time will be lengthened depending on the Battery Pack status. However, note that if the battery capacity indicator lamps do not flash in fault pattern (See "Reading the charging status for Battery Pack"), there is no malfunction.

I. Checking the residual battery capacity



You can check the estimate of how much capacity is left in the Battery Pack and to what extent it is charged. The check can be performed using either the Display Unit's residual battery capacity indicator or the Battery Pack's residual battery capacity indicator lamps.



TIP

- Even if the Battery Pack's capacity reaches 0 (zero), you can still ride the bicycle as a regular bicycle.
- If you are using an old Battery Pack, the residual battery capacity indicator may suddenly display very little power when you start moving. This is not a malfunction. Once riding stabilizes and the load is reduced, the proper value is displayed.

Residual battery capacity indicator display and estimate of residual battery capacity for Display Unit

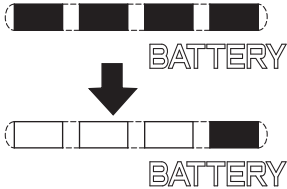

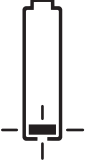
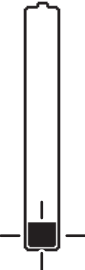
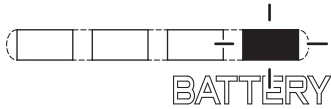
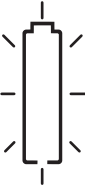





The residual battery capacity can be displayed as a numerical value on the Display Unit.



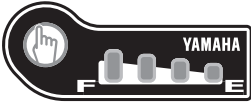



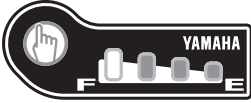

Display of the residual battery capacity for the Display Unit	Display of the residual battery capacity	Applicable situation
<p>(Display A)</p>  <p>(Display C)</p>  <p>(Interface X)</p> 	<p>100–11 %</p>	<p>(Display A and Display C) When you turn on the power of the Display Unit and ride continually after the Battery Pack is fully charged, the segments for the residual battery capacity indicator go out one by one each time the residual battery capacity is reduced by 10 %.</p> <p>(Interface X) When you turn on the power of the Display Unit and ride continually after the Battery Pack is fully charged, the segments for the residual battery capacity indicator go out one by one each time the residual battery capacity is reduced by 25 %.</p>



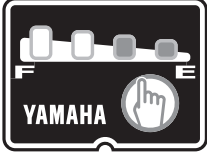

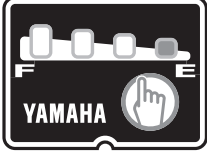
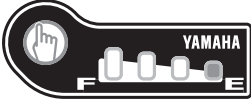

Display of the residual battery capacity for the Display Unit	Display of the residual battery capacity	Applicable situation
<p>(Display A)</p>  <p><0.5 second intervals></p> <p>(Display C)</p>  <p><0.5 second intervals></p> <p>(Interface X)</p>  <p><0.5 second intervals></p>	<p>10–1 %</p>	<p>There is very little residual battery capacity left. Please charge the Battery Pack soon.</p>
<p>(Display A)</p>  <p><0.2 second intervals></p> <p>(Display C)</p>  <p><0.2 second intervals></p> <p>(Interface X)</p>  <p><0.2 second intervals></p>	<p>0 %</p>	<p>There is no more residual battery capacity. Turn off the power for the Display Unit and charge the Battery Pack soon.</p> <p>* Assist is stopped, but you can still ride the bicycle as a regular bicycle.</p>

Display of the battery capacity indicator lamps and the estimate of the residual battery capacity

When checking the residual battery capacity, push the battery capacity indicator button “”.

Display of the battery capacity indicator lamps	Estimate of the residual battery capacity	Applicable situation
<p>(Rear Carrier Battery) (Down Tube Battery)</p>   <p>(Multi Location Battery)</p>   <p>(External Crossover Battery)</p> 	<p>100–76 %</p>	<p>From full charge (100 %), the battery capacity indicator lamps turn off, one by one.</p>
<p>(Rear Carrier Battery) (Down Tube Battery)</p>   <p>(Multi Location Battery)</p>   <p>(External Crossover Battery)</p> 	<p>75–51 %</p>	<p>From full charge (100 %), the battery capacity indicator lamps turn off, one by one.</p>

Display of the battery capacity indicator lamps	Estimate of the residual battery capacity	Applicable situation
<p>(Rear Carrier Battery) (Down Tube Battery)</p>   <p>(Multi Location Battery)</p>   <p>(External Crossover Battery)</p> 	50–26 %	From full charge (100 %), the battery capacity indicator lamps turn off, one by one.
<p>(Rear Carrier Battery) (Down Tube Battery)</p>   <p>(Multi Location Battery)</p>   <p>(External Crossover Battery)</p> 	25–11 %	

Display of the battery capacity indicator lamps	Estimate of the residual battery capacity	Applicable situation
<p>(Rear Carrier Battery) (Down Tube Battery)</p>  <p>(Multi Location Battery)</p>  <p>(External Crossover Battery)</p>  <p>Slow flashing <0.5 second intervals></p>	10-1 %	There is very little battery capacity left.
<p>(Rear Carrier Battery) (Down Tube Battery)</p>  <p>(Multi Location Battery)</p>  <p>(External Crossover Battery)</p>  <p>Fast flashing <0.2 second intervals></p>	0 %	The battery capacity has reached 0 (zero). Please charge the Battery Pack.

J. Pre-operation check

! WARNING

Be sure to perform the inspection before riding the bicycle.
If there is anything you do not understand or find difficult, please consult a bicycle dealer.

NOTICE

- If you confirm there is a fault, have your bicycle inspected at a dealer as soon as possible.
- The power assist mechanism consists of precision parts. Do not disassemble it.

Along with performing the regular inspection before riding the bicycle, also perform the following inspections.

No.	Inspection item	Inspection contents
1	Residual battery capacity	Is enough capacity left in the Battery Pack?
2	Installation status of the Battery Pack	Is it properly installed?
3	Operation of the e-Bike Systems	Do the e-Bike Systems operate when you begin moving?

K. Cleaning, maintenance and storage

! WARNING

For bicycles equipped with a Multi Location Battery 400/500, do not remove the Battery Pack from the bicycle when cleaning the bicycle. Otherwise, water could enter the connector and cause heat generation, smoke and/or a fire.

NOTICE

Do not use high-pressure washers or steam jet cleaners since they can cause water seepage, resulting in property damage or malfunction of the Drive Unit or Display Unit or Battery Pack. Should water get inside one of these units, have a bicycle dealer inspect your bicycle.

Caring for the Battery Pack

Use a moist, tightly-wrung towel to wipe off dirt on the Battery Pack. Do not pour water directly on the Battery Pack, such as with a hose.

NOTICE

Do not clean the contacts by polishing them with a file or using a wire, etc. Doing so could result in a fault.

Maintenance for the Drive Unit

NOTICE

- Because a Drive Unit is a precision machinery, do not disassemble or exert any strong force on it (for example, do NOT hit this product with a hammer). Especially since the crank axle is directly connected to the inside of the Drive Unit, any large damages inflicted on the crank axle may lead to failures.
- To avoid damaging the PW-X3 and PWseries S2 Drive Unit, do not use chain devices with a lower guide.
Strong impacts will be directly transmitted to the Drive Unit and cause damage.

Storage

Store the system in a place that is:

- Flat and stable
- Well ventilated and free from moisture
- Sheltered from the elements and from direct sunlight

Long storage period (1 month or longer) and using it again after a long storage period

- When storing the bicycle for a long period (1 month or longer), remove the Battery Pack and store it using the following procedure.
- Decrease the residual battery capacity to where one or two battery capacity indicator lamps are lit, and store it indoors in a cool 15–25 °C, dry place.
- Check the residual battery capacity once a month, and if only one battery capacity indicator lamp is flashing, charge the Battery Pack for about 10 minutes. Do not let the residual battery capacity become too low.

TIP

- If you leave the Battery Pack at “full charge” or “empty”, it will deteriorate quicker.
 - Due to self-discharge, the Battery Pack slowly loses its charge during storage.
 - The Battery Pack’s capacity decreases over time but proper storage will maximize its service life.
-
- When using it again after a long storage period, be sure to charge the Battery Pack before using it. Also, if you are using it again after storing it for 6 months or longer, have your bicycle inspected and maintained at a dealer.

L. Transport

The Battery Packs are subject to the Dangerous Goods Legislation requirements. When being transported by third parties (e.g. via air transport or forwarding agency), special requirements on packaging and labels must be observed. To prepare the item for shipping, consult a hazardous materials expert. The customer can transport the Battery Packs by road without further requirements. Do not transport damaged Battery Packs.

Tape or mask off open contacts and pack up the Battery Pack in such a manner that it cannot move around in the packaging. Be sure to observe all local and national regulations. In case of questions concerning transport of the Battery Packs, please refer to a bicycle dealer.

M. Disposal

The Drive Unit, Battery Pack, Battery Charger, Display Unit, Speed Sensor Set, accessories and packaging should be sorted for environmental-friendly recycling.

Do not dispose of the bicycle or its components as household waste.

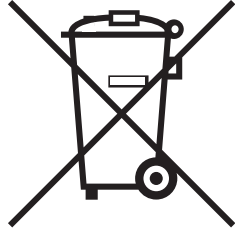

According to the European Directive 2012/19/EU, 2006/66/EC and related national laws, electrical devices/tools that are no longer usable, defective or used Battery Packs/batteries, must be collected separately and disposed of in an environmentally correct manner.

Please return Battery Packs that are no longer usable to a bicycle dealer.

WARNING

Do not dispose of the Battery Pack in a fire or expose it to a heat source. Doing so could cause fire, or explosion, resulting in serious injury or property damage.

N. Simplified declaration of conformity

Hereby, YAMAHA MOTOR CO., LTD. declares that the radio Equipment type [X1R02], [X1R10] and [X2Y] is in compliance with Directive 2014/53/EU.

The full text of the EU declaration of conformity is available at the following internet address:



<https://global.yamaha-motor.com/business/e-bike-systems/document/>

* Applies to Display C and Interface X.

O. Troubleshooting e-Bike Systems

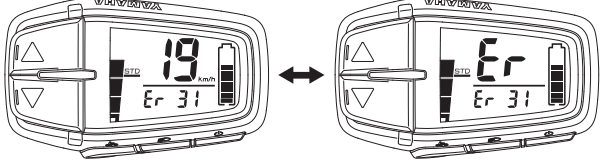

Symptom	Check	Action
Pedaling is difficult.	Is the Display Unit's power on?	Press the power switch on the Display Unit to turn the power on.
	Is the Battery Pack installed?	Install a charged Battery Pack.
	Is the Battery Pack charged?	Charge the Battery Pack.
	Has the bicycle remained not operated for 5 minutes or longer?	Turn the power on again.
	Are you riding on a long inclined road or carrying a heavy load during summertime?	This is not a malfunction. It is a safeguard engaged when the temperature of the Battery Pack or the Drive Unit is too high. Power assist will be restored once the temperature of the Battery Pack or the Drive Unit has decreased. Also, you can make this less likely to occur by shifting to a lower gear than you would usually use (for example, by shifting from second to first gear).
	Is the air temperature low (roughly 10 °C or below)?	During the wintertime, store the Battery Pack indoors before use.
	Are you charging the Battery Pack while it is mounted on the bicycle?	Stop charging the Battery Pack.

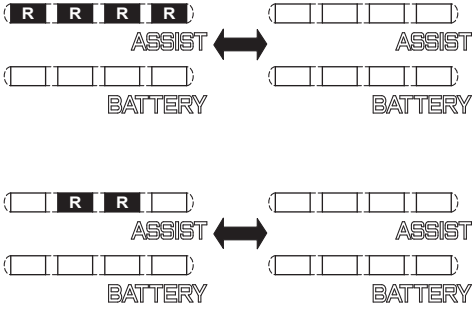

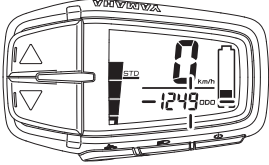
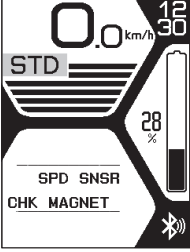
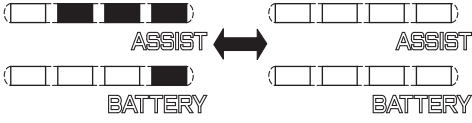
Symptom	Check	Action
<p>The Drive Unit turns on and off while riding.</p>	<p>Is the Battery Pack correctly installed?</p>	<p>Check to make sure the Battery Pack is locked in place. If this problem still occurs with the Battery Pack firmly locked in place, there may be a loose connection with the Battery Pack terminals or wires. Have a bicycle dealer inspect your bicycle.</p>
<p>Strange rumbling or crunching noises come from the Drive Unit.</p>		<p>There could be a problem inside the Drive Unit. Have a bicycle dealer inspect your bicycle.</p>
<p>Smoke or unusual odor comes from the Drive Unit.</p>		<p>There could be a problem inside the Drive Unit. Have a bicycle dealer inspect your bicycle.</p>

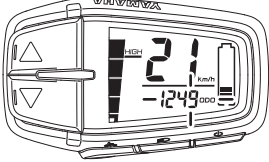
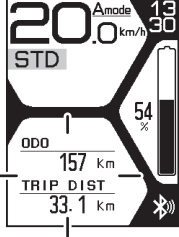
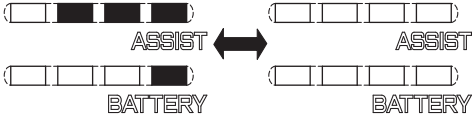
Symptom	Check	Action
<p>(Display A) The main riding display and “Er” are displayed alternately, and an error code is indicated in the function display.</p>  <p>(Display C) Error messages other than those related to the Battery Pack are displayed here as “ER” together with a description of the error underneath.</p>  <p>(Interface X) The battery capacity indicator goes off, and all lamps of the assist mode indicator flash in red or 2 indicator segments of the assist mode indicator flash.</p>  <p>R Red No light</p>		<p>The problem occurs in the e-Bike Systems. Turn off the power and then turn it on again. If the problem cannot be solved, have your bicycle inspected by a dealer as soon as possible.</p>
<p>Traveling range has decreased.</p>	<p>Are you fully charging the Battery Pack?</p> <p>Are you using the system under low-temperature conditions?</p> <p>Is the Battery Pack worn out?</p>	<p>Charge the Battery Pack until full (F).</p> <p>Normal traveling range will be restored when the ambient temperature rises. Additionally, storing the Battery Pack indoors (in a warm location) before use will improve traveling range under cold conditions.</p> <p>Replace the Battery Pack.</p>

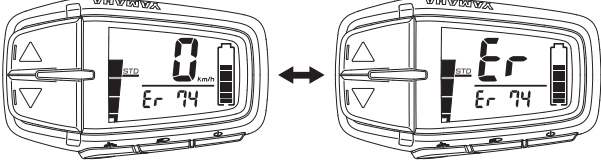
Symptom	Check	Action
<p>(Display A) The speed is not displayed even while riding, and the function display is flashing.</p>  <p>(Display C) An error description is indicated in the function display.</p>  <p>(Interface X) Assist mode indicator and battery capacity indicator will flash. Flashing lamp depends on the situation at that time.</p> 		<p>The speed sensor cannot detect a correct signal. Turn off the power to the Display Unit and then turn it on again. Select the assist mode and then ride for a short distance. Also, make sure the magnet is mounted correctly.</p>

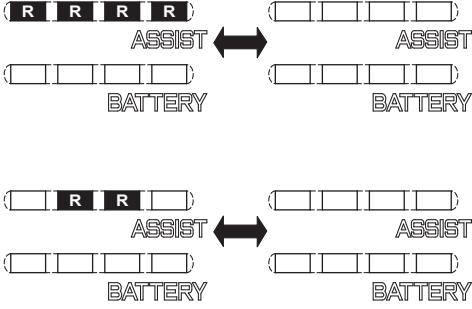
Symptom	Check	Action
<p>(Display A) The speed is displayed but the function display is flashing. (Power assist is stopped.)</p>  <p>(Display C) The function display are flashing. (Power assist is stopped.)</p>  <p>(Interface X) Assist mode indicator and battery capacity indicator will flash. Flashing lamp depends on the situation at that time.</p> 		<p>This is not a malfunction. It is in a state that the operation of the e-Bike Systems is normal. This state may occur depending on the pedaling strength and riding speed, but it returns to normal condition if it is confirmed that the system is normal.</p>

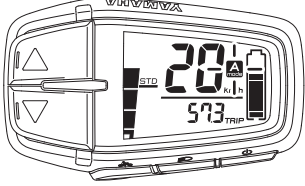
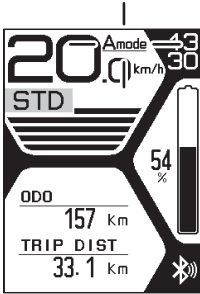
Symptom	Check	Action
<p>(Display A) The main riding display and “Er” are displayed alternately, and an error code is indicated in the function display.</p>  <p>(Display C) Error messages relating to Battery Pack errors are displayed here as “ER” together with “BATTERY” and a description underneath.</p>  <p>(Interface X) The battery capacity indicator goes off, and all lamps of the assist mode indicator flash in red or 2 indicator segments of the assist mode indicator flash.</p>  <p> R Red No light </p>		<p>The problem occurs in the Battery Pack. Turn off the power and then turn it on again. If the problem cannot be solved, have your Battery Pack inspected by a dealer as soon as possible.</p>

Symptom	Check	Action
<p>(Display A) The Automatic Support Mode indicator is flashing.</p>  <p>(Display C) The Automatic Support Mode indicator is flashing.</p>  <p>(Interface X) The rightmost lamp of the assist mode indicator flashes in Turquoise. The other lamps light up as normal to display the current state.</p>  <p>* Depends on the situation at that time. T Turquoise</p>		<p>There could be a problem inside the Drive Unit. Turn off the power to the Display Unit and then turn it on again. If the problem cannot be solved, have your bicycle inspected by a dealer as soon as possible.</p>

Walk assist function

Symptom	Check	Action
The walk assist function turns off.	Is the tire locked for a few seconds?	<p>(Display A and Display C) Release your finger from the walk assist switch for a moment, and after making sure that the tires turn, push the switch again.</p> <p>(Interface X) Release your finger from the assist mode switch (down) for a moment, and after making sure that the tires turn, and then start over the walk assist function from the beginning.</p>
	Did you pedal while the walk assist function was running?	<p>(Display A and Display C) Take your feet off the pedals and remove your finger from the walk assist switch for a moment, and then press it again.</p> <p>(Interface X) Take your feet off the pedals and remove your finger from the assist mode switch (down) for a moment, and then start over the walk assist function from the beginning.</p>
	(Interface X) Does the rightmost lamp of the assist mode indicator light up in purple?	<p>Remove your finger from the assist mode switch (down) for a moment, and then start over the walk assist function from the beginning.</p>

Power supply of external devices via USB connection

* Applies to Display C and Interface X.

Symptom	Check	Action
Power is not supplied.	Is the Display Unit's power on?	Press the power switch on the Display Unit to turn the power on.
	Is the USB version correct?	Use an external device that complies with USB 2.0.
	Is the USB cable type correct?	Use an OTG cable. Also connect the host side to the display.
	Is the USB cable firmly connected?	Reconnect the USB cable.
	Is the USB port or USB plug terminal dirty or wet?	Disconnect the USB cable from the Display Unit and external device. Remove the dirt and water on the USB port and USB plug terminal and reconnect the cable.
	(Display C) Is USB setting set to "COMM"?	Set the USB settings to "Power Supply" by referring to "Settings" or turn off the power and then turn it on again.



Wireless communication



* Applies to Display C and Interface X.

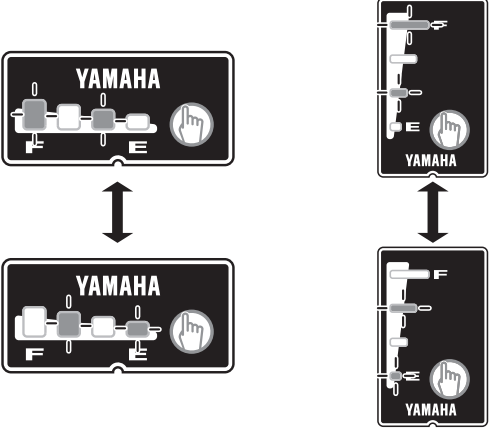
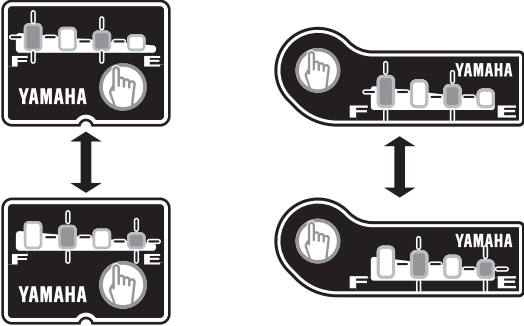

Symptom	Check	Action
Wireless communication cannot be used.	Are both the wireless communication settings of the Display Unit and your wireless communication device turned on?	Set the communication profiles by referring to “Settings”, and then set the correct communication profiles of the wireless communication device or application software.
	Are the communication profiles of the wireless communication device or application software that communicates wirelessly with the communication profiles of the display correct?	
The display values of the external wireless communication device are wrong.	Did you change the settings of the communication profiles?	Reset pairing for a moment, set the communication profiles of the display, and then establish pairing again. For resetting of pairing and the procedure of establishing pairing, refer to the instruction manual supplied with the wireless communication device.

Battery Pack and Battery Charger

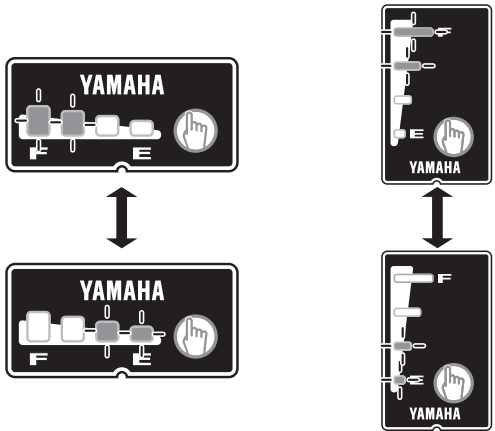
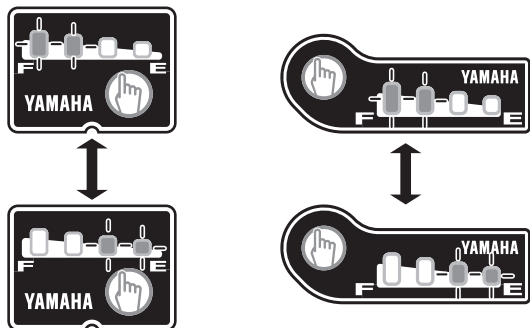
Symptom	Check	Action
Cannot charge	Is the power plug firmly connected? Is the charging plug firmly inserted in the Battery Pack?	Reconnect and try charging again. If the Battery Pack still does not charge, the Battery Charger might be malfunctioning.
	Are the residual battery capacity indicator lamps lit?	Review charging method and try charging again. If the Battery Pack still does not charge, the Battery Charger might be malfunctioning.
	Are the Battery Charger or Battery Pack contact terminals dirty or wet?	Remove the Battery Pack from the Battery Charger and the charging plug from the socket. Use a dry cloth or cotton swab to clean the Battery Charger and Battery Pack contact terminals. Then reconnect both the Battery Pack and the Battery Charger.

Symptom	Check	Action
<p>(Rear Carrier Battery) (Down Tube Battery)</p>  <p>(Multi Location Battery)</p>  <p>(External Crossover Battery)</p> 	<p>There is a contact fault in the contact terminals.</p>	<p>Remove the Battery Pack from the bicycle. Then connect the charging plug into the Battery Pack. (If battery capacity indicator lamps still flash alternately, there might be a fault in the Battery Pack). When the Battery Pack is remounted on the bicycle and the power switch of the Display Unit is pressed, if battery capacity indicator lamps still flash alternately, there might be a fault in the Drive Unit.</p>

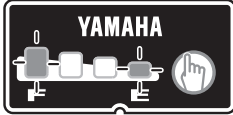
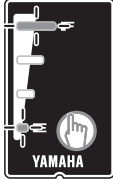
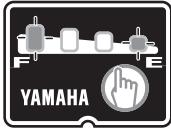
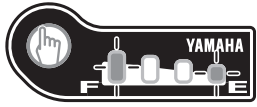
Symptom	Check	Action
<p>(Rear Carrier Battery) (Down Tube Battery)</p> 	<p>There is a contact fault in the contact terminals.</p>	<p>Remove the Battery Pack from the Battery Charger, mount the Battery Pack on the bicycle and press the power switch of Display Unit. When the charging plug is reconnected into the Battery Pack, if battery capacity indicator lamps still flash simultaneously, there might be a fault in the Battery Charger.</p>
<p>(Multi Location Battery)</p>  <p>(External Crossover Battery)</p> 	<p>Is the charging connector on the Battery Pack wet?</p>	<p>Clean the charging connector and charging plug. Then dry them. Afterwards, connect the charging plug to the charging connector.</p>

Symptom	Check	Action
<p>Both side battery capacity indicator lamps are flashing simultaneously.</p> <p>(Rear Carrier Battery) (Down Tube Battery)</p>   <p>(Multi Location Battery)</p>   <p>(External Crossover Battery)</p> 		<p>The Battery Pack protection feature has been activated and the system cannot be used. Replace the Battery Pack at a bicycle dealer as soon as possible.</p>
<p>The Battery Charger emits abnormal noises, foul odors or smoke.</p>		<p>Unplug the charging plug and immediately cease operation. Have a bicycle dealer inspect your bicycle.</p>
<p>The Battery Charger becomes hot.</p>	<p>It is normal for the Battery Charger to become somewhat warm during charging.</p>	<p>If the Battery Charger is too hot to be touched by hand, unplug the charging plug, wait for it to cool, and consult a bicycle dealer.</p>
<p>After charging, all of the battery capacity indicator lamps do not light up when the battery capacity indicator button “” is pressed.</p>	<p>Has the charging plug been unplugged or the Battery Pack removed during charging?</p>	<p>Charge the Battery Pack again.</p>
	<p>Did you start charging with the Battery Pack at a high temperature, such as immediately after use?</p>	<p>Move to a location where the Battery Pack temperature can reach the range where charging is possible (15–25 °C), and then start charging again.</p>
<p>After disconnecting the charging plug on the Battery Charger from the Battery Pack, the battery capacity indicator lamps continue to light up.</p>	<p>Is the charging connector on the Battery Pack wet?</p>	<p>Clean the charging connector and charging plug. Then dry them.</p>

P. Specifications

Drive Unit

PWseries CE	Range of assist speed		0 to less than 25 km/h
	Electric motor	Type	Permanent Magnet Synchronous Motor
		Rated output	250 W
	Assist power control method		Control method depends on pedaling torque and bicycle speed
PWseries TE	Range of assist speed		0 to less than 25 km/h
	Electric motor	Type	Permanent Magnet Synchronous Motor
		Rated output	250 W
	Assist power control method		Control method depends on pedaling torque and bicycle speed
PWseries ST	Range of assist speed		0 to less than 25 km/h
	Electric motor	Type	Permanent Magnet Synchronous Motor
		Rated output	250 W
	Assist power control method		Control method depends on pedaling torque and bicycle speed
PW-X2	Range of assist speed		0 to less than 25 km/h
	Electric motor	Type	Permanent Magnet Synchronous Motor
		Rated output	250 W
	Assist power control method		Control method depends on pedaling torque and bicycle speed
PW-X3	Range of assist speed		0 to less than 25 km/h
	Electric motor	Type	Permanent Magnet Synchronous Motor
		Rated output	250 W
	Assist power control method		Control method depends on pedaling torque and bicycle speed
PWseries S2	Range of assist speed		0 to less than 25 km/h
	Electric motor	Type	Permanent Magnet Synchronous Motor
		Rated output	250 W
	Assist power control method		Control method depends on pedaling torque and bicycle speed

Battery Pack

Rear Carrier Battery 400/500	Type	PASB5 (Lithium-ion battery)
	Voltage	36 V
	Capacity	11 Ah/13.6 Ah
	Number of battery cells	40
Down Tube Battery 400/500	Type	PASB5 (Lithium-ion battery)
	Voltage	36 V
	Capacity	11 Ah/13.6 Ah
	Number of battery cells	40
Multi Location Battery 400/500	Type	PASB6 (Lithium-ion battery)
	Voltage	36.5 V/36 V
	Capacity	11 Ah/13.4 Ah
	Number of battery cells	40
Multi Location Battery 600	Type	PASB4 (Lithium-ion battery)
	Voltage	36 V
	Capacity	16.5 Ah
	Number of battery cells	50
External Crossover Battery 400/500	Type	PASB6 (Lithium-ion battery)
	Voltage	36.5 V/36 V
	Capacity	11 Ah/13.4 Ah
	Number of battery cells	40

Product Information 	Product Name	<ul style="list-style-type: none"> • Down Tube Battery 500 • Multi Location Battery 400/500/600 • External Crossover Battery 400/500
	Manufacturer	YAMAHA MOTOR CO., LTD. 2500 Shingai, Iwata, Shizuoka 438-8501, Japan

* Even if a Battery Pack is not listed in the product name field of the table above, it is UKCA conformed if the UKCA marking is placed on it.



Battery Charger

PASC9	Input voltage	AC 220–240 V/50–60 Hz
	Maximum output voltage	DC 42 V
	Maximum output current	DC 4.0 A
	Maximum consumed power	310 VA/180 W (Charged at AC 240 V)
	Applicable type Battery Pack	PASB6
PASC10	Input voltage	AC 220–240 V/50–60 Hz
	Maximum output voltage	DC 42 V
	Maximum output current	DC 4.0 A
	Maximum consumed power	310 VA/180 W (Charged at AC 240 V)
	Applicable type Battery Pack	PASB2/PASB4/PASB5

Battery Pack and Battery Charger information is also available at the following internet address:
<https://global.yamaha-motor.com/business/e-bike-systems/products/battery-charger/>

Display Unit

Display A	Power supply portion	—
	Wireless communication portion	—

Display C	Power supply portion	USB port type	USB2.0 Micro-B
		Output current	Max. 1000 mA
		Rated voltage	5 V
	Wireless communication portion	Communication range	Line-of-sight distance approx. 1 m (3 ft) without interference
		Frequency band	2.4 GHz band (2.400–2.4835 GHz)
		Modulation method	GFSK
		Communication system	Bluetooth version 4.0 (Bluetooth low energy technology)
		Output power	–5.39 dBm (e.i.r.p.)
	Product Information 	Supported profiles	CSCP ^{*1} CPP ^{*2} YEP1.0 ^{*3}
		Model No.	X1R02/X1R10
		Manufacturer	YAMAHA MOTOR CO., LTD. 2500 Shingai, Iwata, Shizuoka 438-8501, Japan
		Trade mark/ Trade name	

*1 CSCP (Cycling Speed and Cadence Profile)

Corresponds to the wheel revolution data and crank revolution data.

*2 CPP (Cycling Power Profile)



Corresponds to the wheel revolution data, crank revolution data, instantaneous power, and accumulated energy.

*3 YEP1.0

The e-Bike profile preset by YAMAHA MOTOR CO., LTD.

Navigation information (Compass) and fitness support (Fitness) can be displayed on the Display Unit by pairing the smartphone application with YEP1.0.

- Communication is not necessarily guaranteed with all wireless communication devices that have the same profiles as this system.
Even when a device complies with the specification for Bluetooth low energy technology, there may be cases where the characteristics, specifications, or communicative environment of the device with this technology make it impossible to connect, or may result in different control methods, display or operation.
- YAMAHA MOTOR CO., LTD. can not be held liable in any way for damages or other loss resulting from information leaks during the communication via Bluetooth low energy technology.

Interface X	Power supply portion	USB port type	USB2.0 Micro-B		
		Output current	Max. 1200 mA		
		Rated voltage	5 V		
	Wireless communication portion	Communication range	Line-of-sight distance approx. 1 m (3 ft) without interference		
		Frequency band	2.4 GHz band (2.400–2.4835 GHz)		
		Modulation method	GFSK		
		Communication system	Bluetooth version 5.0 (Bluetooth low energy technology)	ANT+	
		Output power	−9.27 dBm (e.i.r.p.)	—	
		Supported profiles	CSCP ^{*1} CPP ^{*2} YEP1.0 ^{*3}	S&C ^{*4} PWR ^{*5} LEV ^{*6}	
	Product Information 	Model No.	X2Y		
		Manufacturer	YAMAHA MOTOR CO., LTD. 2500 Shingai, Iwata, Shizuoka 438-8501, Japan		
		Trade mark/ Trade name			

*1 CSCP (Cycling Speed and Cadence Profile)

Corresponds to the wheel revolution data and crank revolution data.

*2 CPP (Cycling Power Profile)

Corresponds to the wheel revolution data, crank revolution data, instantaneous power, and accumulated energy.

*3 YEP1.0

The e-Bike profile preset by YAMAHA MOTOR CO., LTD.

Navigation information (Compass) and fitness support (Fitness) can be displayed on the Display Unit by pairing the smartphone application with YEP1.0.

*4 S&C (Speed and Cadence)

Corresponds to the wheel revolution data and crank revolution data.

*5 PWR (Power)

Corresponds to the crank revolution data, accumulated power, and instantaneous power.

*6 LEV (Light Electric Vehicle)

Commands from the display are not supported.

Send the following data to the display.

(Travel mode, Temperature (Battery, Motor), Speed, Odometer, Remaining range, Fuel consumption, Battery %, Wheel circumference, Error code)

- Communication is not necessarily guaranteed with all wireless communication devices that have the same profiles as this system.
Even when a device complies with the specification for Bluetooth low energy technology, there may be cases where the characteristics, specifications, or communicative environment of the device with this technology make it impossible to connect, or may result in different control methods, display or operation.
- YAMAHA MOTOR CO., LTD. can not be held liable in any way for damages or other loss resulting from information leaks during the communication via wireless communication functions.

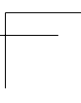
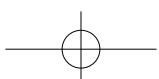
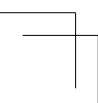
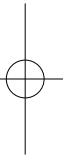
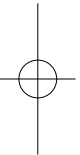
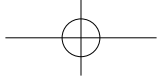
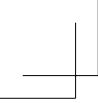

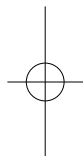
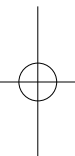
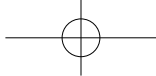

PRINTED IN JAPAN

